



FEATURES

- 1. Compact Size**
W 40 × L 58 × H 25.5 mm
W 1.575 × L 2.283 × H 1.004 inch
- 2. With terminal cover for safety (output side only).**
* Cover on input side available as option.
- 3. Mounting pitch 47.5 mm 1.870 inch**
- 4. Internal diode protects element on output side**
- 5. With LED indication for operation status verification**

TYPICAL APPLICATIONS

- Photovoltaic power generation system
 - Storage battery system
 - For control of all types of business equipment and industrial use DC heaters/motors, etc.
- * Please visit our website to find out the latest about international standards compliance.

ORDERING INFORMATION

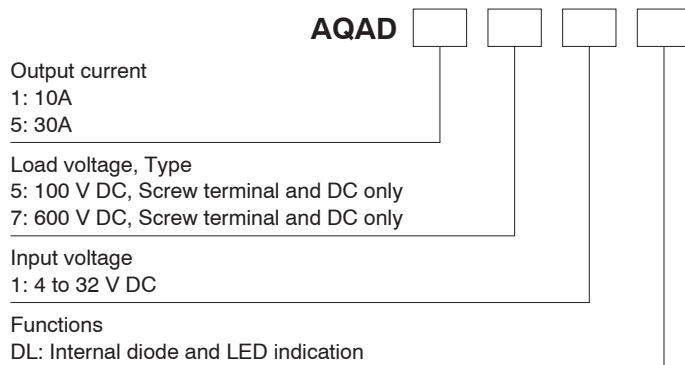

TYPES

1. AQ-A Solid State Relays (DC only)

Type	Load current	Load voltage	Input voltage	Part No.
DC only	30A	100V DC	4 to 32V DC	AQAD551DL
	10A	600V DC		AQAD171DL

Standard Packing; carton: 2 pcs., case: 60 pcs.

2. Accessories

Type	Part No.	Packaged quantity
Standard heat sink	AQP-HS-J25A	No carton, 5 in a case
Slim heat sink (45mm 1.772inch wide) (Mountable on a DIN rail)	AQP-HS-SJ20A	No carton, 8 in a case
DIN rail mounting plate	AQP-DPJ	No carton, 50 in a case
Terminal cover	AQA801	No carton, 50 in a case
Mounting rail	AT8-DLA1	1 in a carton, 100 in a case
Fastening plate	ATA4806	1 in a carton, 200 in a case

AQ-A (AQAD)

RATING

1. Ratings (Measurement condition: at 20°C 68°F, Input ripple: 1% or less)

Item	Part No.	AQAD551DL	AQAD171DL	Remarks
Input side	Input voltage	4 to 32V DC		
	Input current	Max. 20mA		
	Drop-out voltage	Min. 1V		
Output side	Max. load current (DC)	30A	10A	
	Peak load current	90A (V _L = 60V DC)	20A (V _L = 600V DC)	100 ms (1 shot)
	Load voltage (DC)	100V	600V	Absolute maximum rating
	"OFF-state" leakage current	Max. 100μA		V _L = Max.
	"ON" resistance	Max. 20mΩ	Max. 200mΩ	at Max. carrying current
	Max. power dissipation	20W		

2. Characteristics (Measurement condition: at 20°C 68°F, Input ripple: 1% or less)

Item	AQAD551DL	AQAD171DL	Remarks
Operate time	Max. 10ms	Max. 5ms	V _{in} = 4 V, I _L = 1 A, V _L = 10 V Resistance load
Release time	Max. 3ms	Max. 1ms	V _{in} = 4 V, I _L = 1 A, V _L = 10 V Resistance load
Insulation resistance	100MΩ between input and output		at 500V DC
Breakdown voltage	4,000 Vrms between input and output 2,500 Vrms between input, output and case		for 1min.
Vibration resistance	10 to 55Hz double amplitude of 1.5mm .059inch		X, Y, Z axes
Shock resistance	Min. 980 m/s ²		X, Y, Z axes
Ambient temperature	-20°C to +80°C -4°F to +176°F		Non-condensing at low temperatures
Storage temperature	-20°C to +85°C -4°F to +185°F		Non-condensing at low temperatures
Max. switching frequency	0.5 times/s		V _{in} = 4 V, duty = 50%, I _L = Max., V _L = Max.

Note: V_{in} is input voltage, I_L is load current, and V_L is load voltage.

REFERENCE DATA

1. Load current vs. ambient temperature characteristics

Use load current within range specified in the figure below.

Tested condition

With external heat sink

When using standard heat sink (AQP-HS-J25A) or slim heat sink (AQP-HS-SJ20A)

1) If attached to a heat sink, use a heat conductive compound (Ex. Momentive Performance Materials Inc. YG6111 or TSK5303) of similar coating to improve cooling.

Without external heat sink

If the mounting surface is not metallic and a heat sink is not used, expose the bottom surface and plate surface to improve heat dissipation.

(1) 30A type (AQAD551DL)

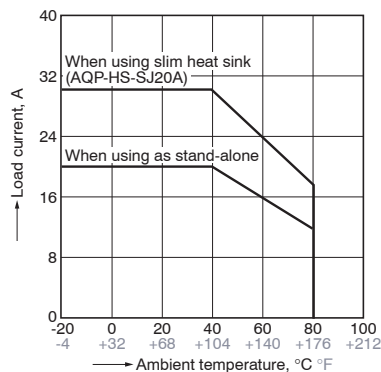

(2) 10A type (AQAD171DL)

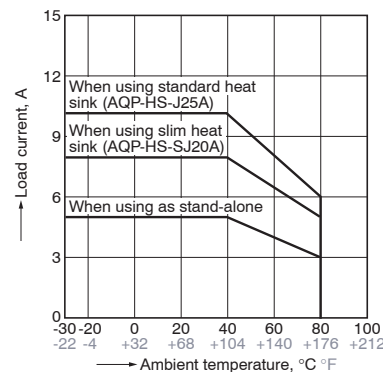

2. Max. switching frequency vs. load voltage × load current characteristics

(1) 30A type (AQAD551DL)

Ambient temperature: 20°C 68°F

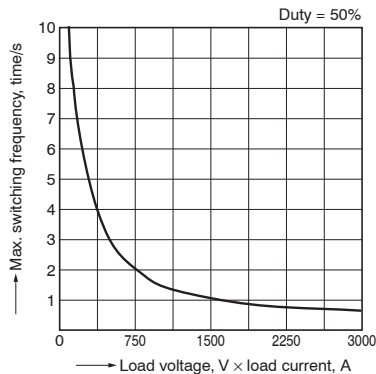

(2) 10A type (AQAD171DL)

Ambient temperature: 20°C 68°F

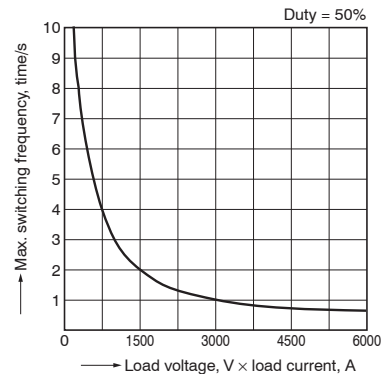

3. Input current vs. input voltage characteristics

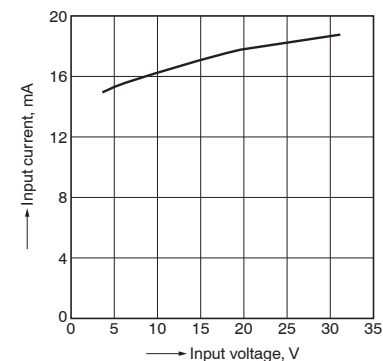

DIMENSIONS (mm inch)

Download [CAD Data](#) from our Web site.

[CAD Data](#)



External dimensions

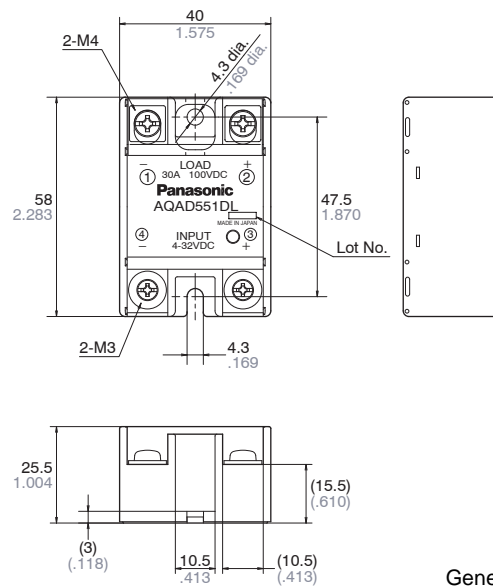

Schematic

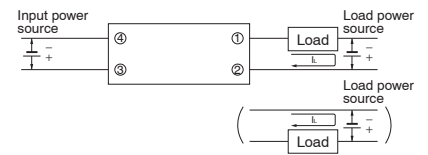

Mounting dimensions

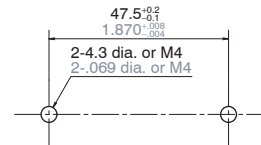

General tolerance: $\pm 1.0 \pm .039$

ACCESSORIES (mm inch)

Download [CAD Data](#) from our Web site.

AQP-HS-SJ20A Slim Heat Sink

[CAD Data](#)

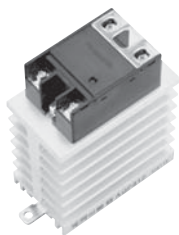

External dimensions

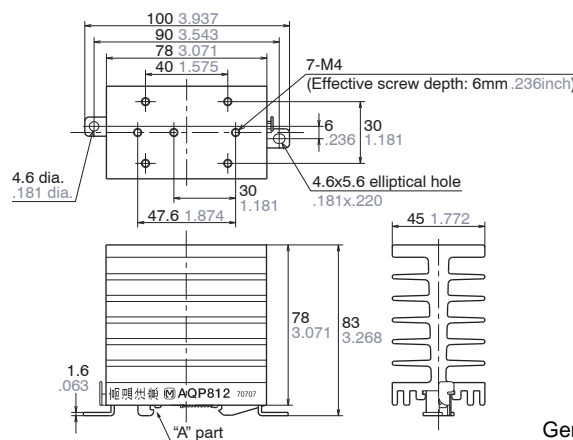

Mounting dimensions

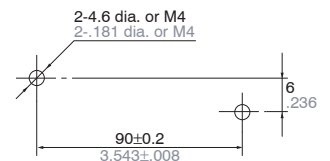

General tolerance: $\pm 1.0 \pm .039$

Note: When using on a DIN rail, please install so that the "A" part is on top.

AQ-A (AQAD)

AQP-HS-J25A Standard Heat Sink

[CAD Data](#)

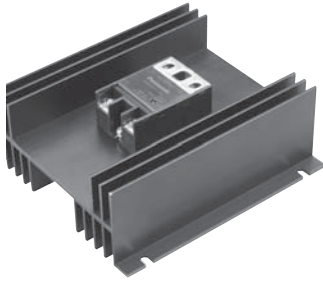

External dimensions

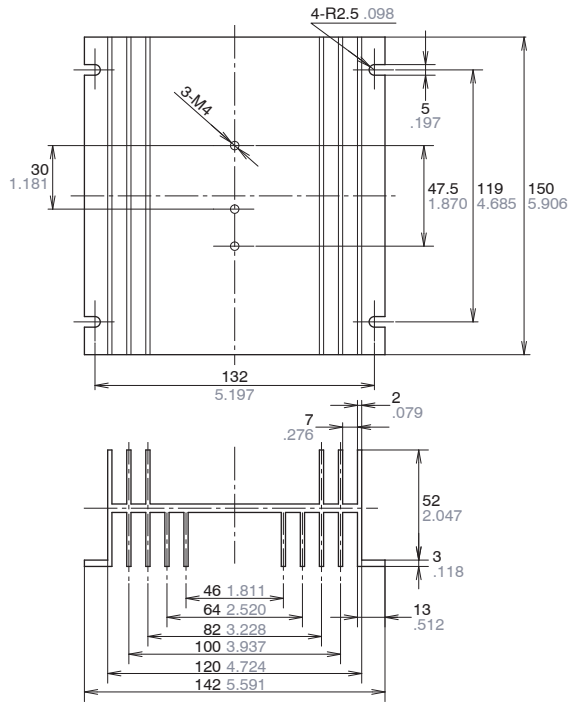

Mounting dimensions

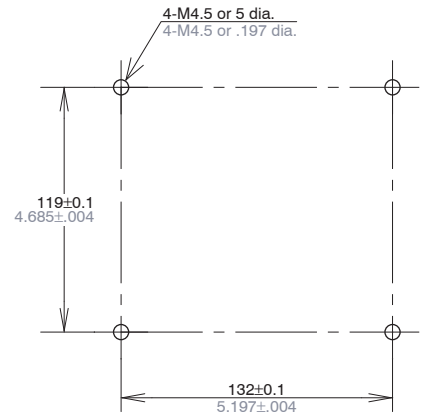

General tolerance: $\pm 1.0 \pm .039$

AQP-DPJ DIN Rail Mounting Plate

[CAD Data](#)



External dimensions

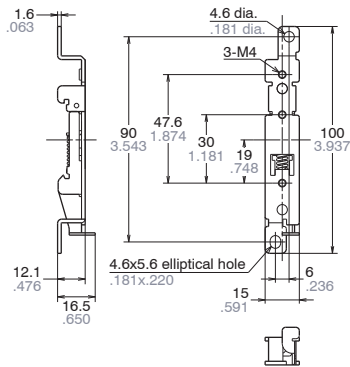

AT8-DLA1 Mounting Rail

[CAD Data](#)

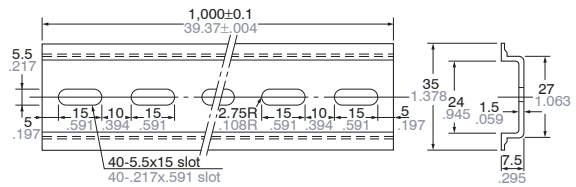

ATA4806 Fastening plate

[CAD Data](#)

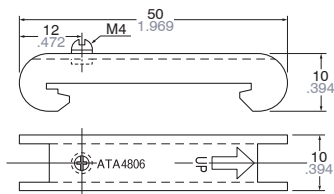

CAUTIONS FOR USE

1. Derating design

Derating is essential in any reliable design and is a significant factor for product life. Even if the conditions of use (temperature, current, voltage, etc.) of the product fall within the absolute maximum ratings, reliability can be reduced remarkably when continually used under high load (high temperature, high humidity, high current, high voltage, etc.). Therefore, please derate sufficiently below the absolute maximum rating and verify operation of the actual design before use.

2. Noise and surge protection at the input side

A high noise surge voltage applied to the SSR input circuit can cause malfunction or permanent damage to the device. If such a high surge is anticipated, use C or R noise absorber in the input circuit.

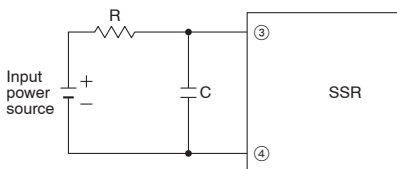

3. If the polarity of the input voltage of input side is reversed

Reversing the polarity may cause permanent damage to the device. Take special care to avoid polarity reversal.

4. In the case of input voltage containing ripple

If the input voltage contains ripple, the peak of the ripple should not exceed the maximum rated control voltage (32V), and the bottom of the ripple should exceed the minimum rated control voltage (4V).

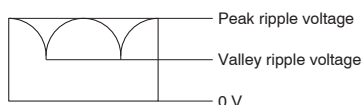

5. If the polarity of the load voltage of output side is reversed

Although the built-in diode for protection against reverse connection will prevent damage from occurring if the output terminals are connected with reverse polarity, please be aware that the circuit will short.

6. Spike voltage

If an inductive load generates spike voltages which exceed the absolute maximum rating, the spike voltage must be limited. Typical circuits are shown below.

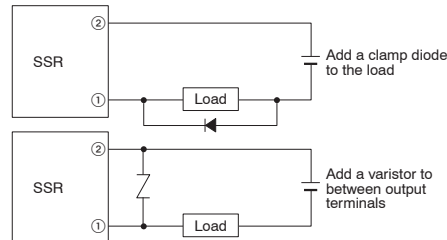

Even if spike voltages generated at the load are limited with a clamp diode or varistor if the circuit wires are long, spike voltages will occur by inductance. Keep wires as short as possible to minimize inductance.

7. Others

- 1) If an SSR is used in close proximity to another SSR or heat-generating device, its ambient temperature may exceed the allowable level. Carefully plan SSR layout and ventilation.
- 2) Terminal connections should be made by referring to the associated wiring diagram.
- 3) When mounting a heat sink, coat it with a heat conducting compound or similar in order to improve the heat dissipation effect.
- 4) The product is hot during and immediately after operation. Use caution.
- 5) When mounting a slim heat sink (AQP-HS-SJ20A) on a DIN rail, mount it as per the instructions in Note of the dimensional drawing. Mounting in the opposite direction may cause disengagement due to vibration or impact.
- 6) For higher reliability, check device quality under actual operating conditions.
- 7) As a guide, the tightening torque for the screw terminals should be approximately 1.0 N·m on the output side and approximately 0.5 N·m on the input side.

8. Transportation and storage

1) Extreme vibration during transport will warp the terminal or damage the relay. Handle the carton and case with care.
2) Storage under extreme conditions will cause external appearance defects, and deterioration of the characteristics. The following storage conditions are recommended:

- Temperature: 0 to 45°C 32 to 113°F
- Humidity: Less than 70% R.H.
- Atmosphere: No harmful gasses such as sulfurous acid gas, minimal dust.

Cautions for Use