

STANDOFFS, THREADED, ROUND

STANDOFFS THREADED, ROUND

588-9XXX-XXX-02 BRASS PER ASTM B16
688A-9XXX-XXX-XX ALUMINUM PER ASTM B211

BASIC PART NO. FINISH

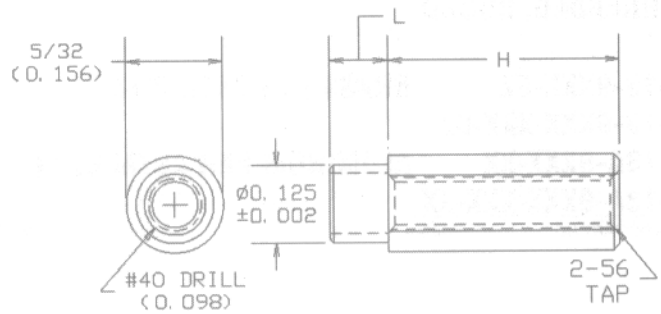

FOR H=.750 AND H=1.000 ONLY,
TAPPED BOTH ENDS, NOT TAPPED THRU

BOARD THICKNESS	H	L	BRASS	ALUMINUM	BOARD THICKNESS	H	L	BRASS	ALUMINUM
1/32	.125	.062	588-9208-062	688A-9208-062	1/8	.125	.156	588-9211-156	688A-9211-156
1/32	.188	.062	588-9222-062	688A-9222-062	1/8	.188	.156	588-9225-156	688A-9225-156
1/32	.250	.062	588-9229-062	688A-9229-062	1/8	.250	.156	588-9232-156	688A-9232-156
1/32	.375	.062	588-9243-062	688A-9243-062	1/8	.375	.156	588-9246-156	688A-9246-156
1/32	.500	.062	588-9257-062	688A-9257-062	1/8	.500	.156	588-9260-156	688A-9260-156
1/32	.625	.062	588-9271-062	688A-9271-062	1/8	.625	.156	588-9274-156	688A-9274-156
1/32	.750	.062	588-9285-062	688A-9285-062	1/8	.750	.156	588-9288-156	688A-9288-156
1/32	1.000	.062	588-9313-062	688A-9313-062	1/8	1.000	.156	588-9316-156	688A-9316-156
1/16	.125	.094	588-9209-094	688A-9209-094	3/16	.125	.219	588-9213-219	688A-9213-219
1/16	.188	.094	588-9223-094	688A-9223-094	3/16	.188	.219	588-9227-219	688A-9227-219
1/16	.250	.094	588-9230-094	688A-9230-094	3/16	.250	.219	588-9234-219	688A-9234-219
1/16	.375	.094	588-9244-094	688A-9244-094	3/16	.375	.219	588-9248-219	688A-9248-219
1/16	.500	.094	588-9258-094	688A-9258-094	3/16	.500	.219	588-9262-219	688A-9262-219
1/16	.625	.094	588-9272-094	688A-9272-094	3/16	.625	.219	588-9276-219	688A-9276-219
1/16	.750	.094	588-9286-094	688A-9286-094	3/16	.750	.219	588-9290-219	688A-9290-219
1/16	1.000	.094	588-9314-094	688A-9314-094	3/16	1.000	.219	588-9318-219	688A-9318-219
3/32	.125	.125	588-9210-125	688A-9210-125	1/4	.125	.281	588-9214-281	688A-9214-281
3/32	.188	.125	588-9224-125	688A-9224-125	1/4	.188	.281	588-9228-281	688A-9228-281
3/32	.250	.125	588-9231-125	688A-9231-125	1/4	.250	.281	588-9235-281	688A-9235-281
3/32	.375	.125	588-9245-125	688A-9245-125	1/4	.375	.281	588-9249-281	688A-9249-281
3/32	.500	.125	588-9259-125	688A-9259-125	1/4	.500	.281	588-9263-281	688A-9263-281
3/32	.625	.125	588-9273-125	688A-9273-125	1/4	.625	.281	588-9277-281	688A-9277-281
3/32	.750	.125	588-9287-125	688A-9287-125	1/4	.750	.281	588-9291-281	688A-9291-281
3/32	1.000	.125	588-9315-125	688A-9315-125	1/4	1.000	.281	588-9319-281	688A-9319-281

- FOR BRASS PARTS, ADD -02 SUFFIX TO PART NUMBER FOR STANDARD NICKEL FINISH
- FOR ALUMINUM PARTS, ADD -17 SUFFIX TO PART NUMBER FOR STANDARD NON-CHROMATE CLEAR PROTECTIVE COATING OR -16 FOR YELLOW IRRIDITE FINISH.

H	ANVIL	PUNCH
.125	TA156-125	TP125-98
.188		
.250	TA156-250	TP125-98
.375		
.500	TA156-500	TP125-98
.625		
.750	TA156-750	TP125-98
1.000		

FOR ADDITIONAL SIZES AND MATERIALS, CONTACT FACTORY

