

DASH NO.	M CODE	MADE FROM
----------	--------	-----------

# GSD

M39012/16-0020

REVISIONS	
ISSUE	CHANGES
0	ER 39010 DCT 2/3/4
1	CN 39116 E DCT 7/12/4

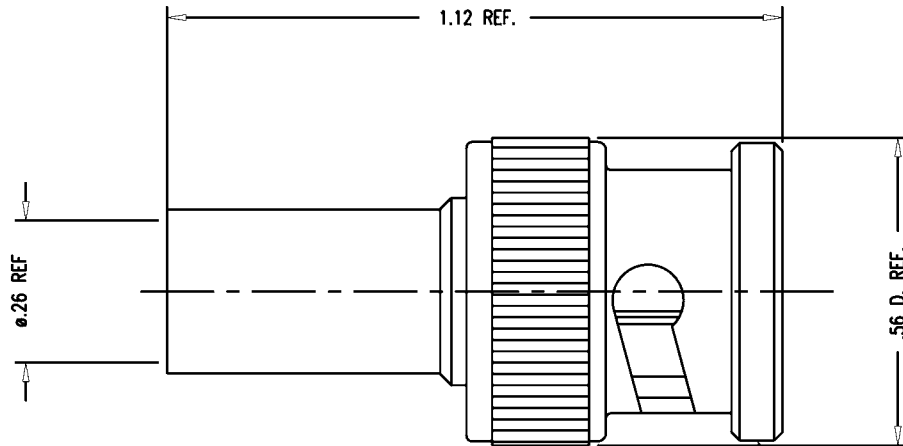

STAMP: 91836 M39012/16-0020  
755-118-5 XXXX  
DATE CODE

**NOTES:**

- FOR USE WITH RG-302 CABLE GROUPS.
- FOR CABLING INSTRUCTIONS SEE CP-465.
- FOR CRIMPING USE DIE KTH-2002.
- INTERFACE PER MIL-STD-348, FIG. 301-1.
- CENTER CONTACT TO BE SUPPLIED UNASSEMBLED.
- MATERIALS:  
INSULATOR: TEFLON, ASTM-D4894  
GASKET: SILICONE RUBBER, A-A-59588  
SPRING WASHER: BER. COP. ASTM-B-196  
OUTER CONTACT: BER. COP. ASTM-B-196  
CRIMP SLEEVE; COMM. BRONZE, ASTM-B16, H02  
ALL OTHER METAL PARTS: BRASS, ASTM-B36
- FINISHES:  
CENTER CONTACT: GOLD PLATE PER ASTM-B488  
ALL OTHER METAL PARTS: SILVER PLATE PER ASTM-B700
- ELECTRICAL CHARACTERISTICS:  
NOMINAL IMPEDANCE: 50 OHM  
FREQUENCY RANGE: DC TO 4 GHz  
VOLTAGE RATING: 500 VOLTS RMS

SCALE 4:1	
APPROX SURFACE AREA	
755-118-5	
USED ON	
REF:	
PLUG, BNC	
DRAWN DCT	DATE 2/2/4
DESIGN DCT	DATE 10/24/3
APPR.	DATE
 ELECTRONICS CO., INC. ROCK HILL, SOUTH CAROLINA 29730	
M39012/16-0020	

# GSD