

MICRO SWITCH
a Honeywell Division
FED. MFG. CODE 91929

SWITCH - ENCLOSED

CATALOG LISTING
1EN1-5

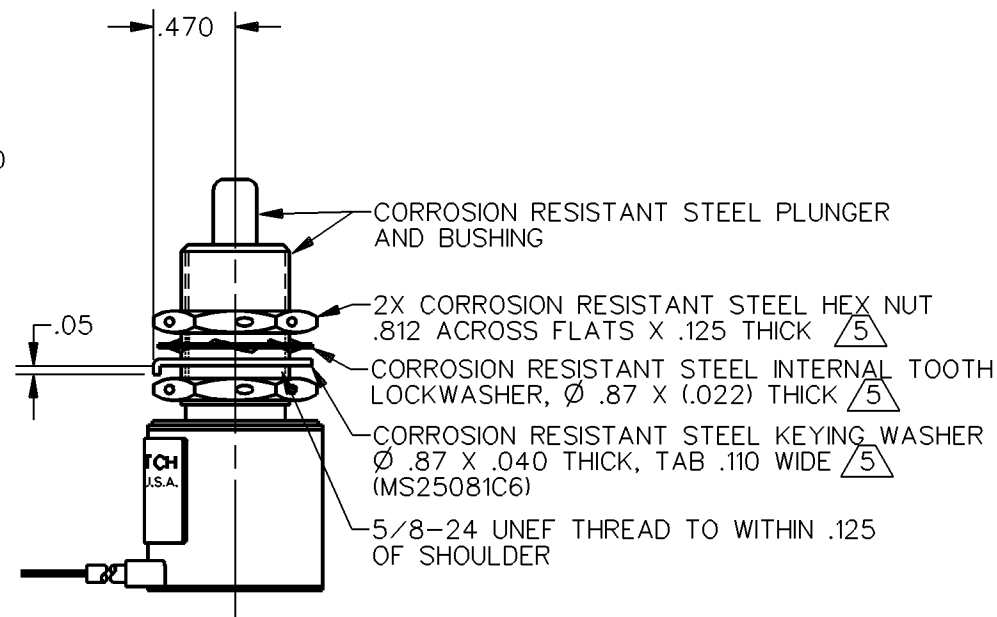
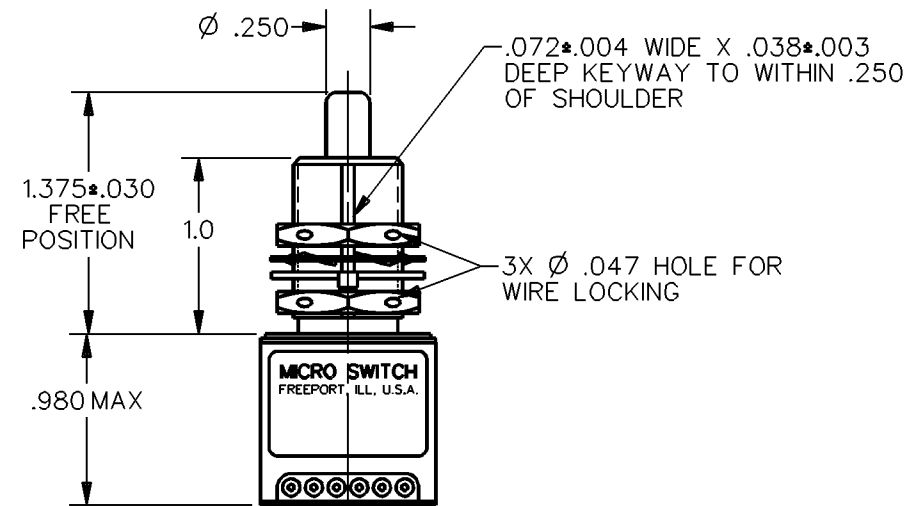
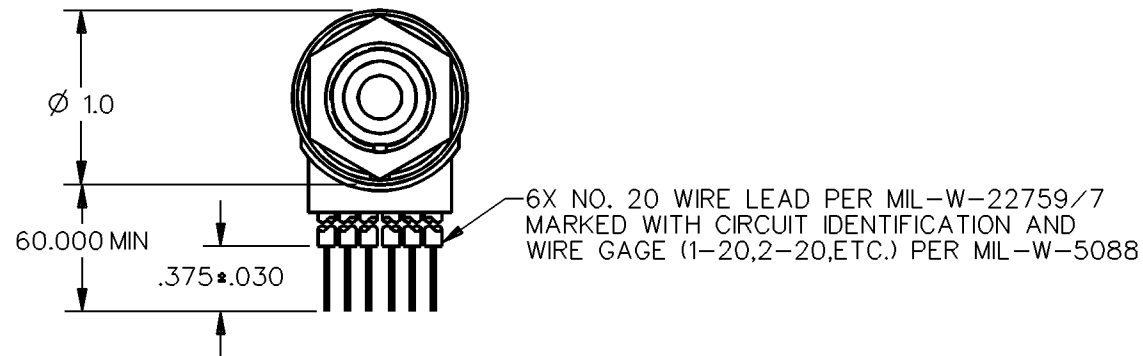
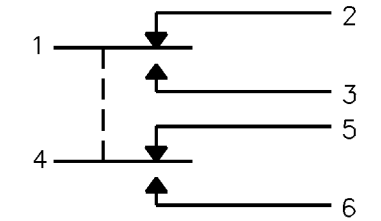

- NOTES
- 1 - CORROSION RESISTANT STEEL ENCLOSURE
 - 2 - SWITCH SEALED PER MIL-S-8805 SYMBOL 4
 - 3 - COINCIDENCE OF OPERATING AND RELEASING POINTS: .010 OF PLUNGER TRAVEL
 - 4 - CIRCUIT DIAGRAM, CATALOG LISTING AND DATE CODE ARE SHOWN ON NAMEPLATE
- △ 5 - HARDWARE MAY BE PACKAGED UNASSEMBLED PER MIL-S-8805

THIS DRAWING COVERS A PROPRIETARY ITEM AND IS THE PROPERTY OF MICRO SWITCH, A DIVISION OF HONEYWELL. THIS DRAWING IS NOT TO BE COPIED OR USED WITHOUT THE APPROVAL OF MICRO SWITCH

THIRD ANGLE PROJECTION

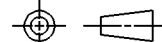

SCALE FULL

DO NOT SCALE PRINT

UNLESS OTHERWISE SPECIFIED TOLERANCES ARE

ONE PLACE (.0) ± .030

TWO PLACE (.00) ± .015

THREE PLACE (.000) ± .005

ANGLES ±

WEIGHT 7 OZ MAX

ANSI Y14.5M-1982 APPLIES

CHARACTERISTICS	
OPERATING FORCE	6-12 LB
FULL OVERTRAVEL FORCE	30 LB MAX
RELEASE FORCE	4 LB MIN
PRETRAVEL	.040 MAX
DIFFERENTIAL TRAVEL	.020 MAX
OVERTRAVEL	.250 MIN

ELECTRICAL DATA		
CONTACT ARRANGEMENT 2X S P D T		
LOAD	28 VDC	
	SEA LEVEL	50,000 FT.
RES	4	4
IND	2	2
MOTOR	4	

CATALOG LISTING 1EN1-5
 ISSUE 15
 REVISIONS
 A 00 77504A L J F 15 MAR 94
 CHECK
 CHECK
 DDM/CAD DRAWN L J F 15 MAR 94 CHECK

REPLACES
 RELEASE NO. PR-1745