

HONEYWELL PART NUMBER
26ET24-3
FAA-PMA 

REV	DOCUMENT	CHANGED BY	CHECK
11	0006860	CVS 04AUG04	AK

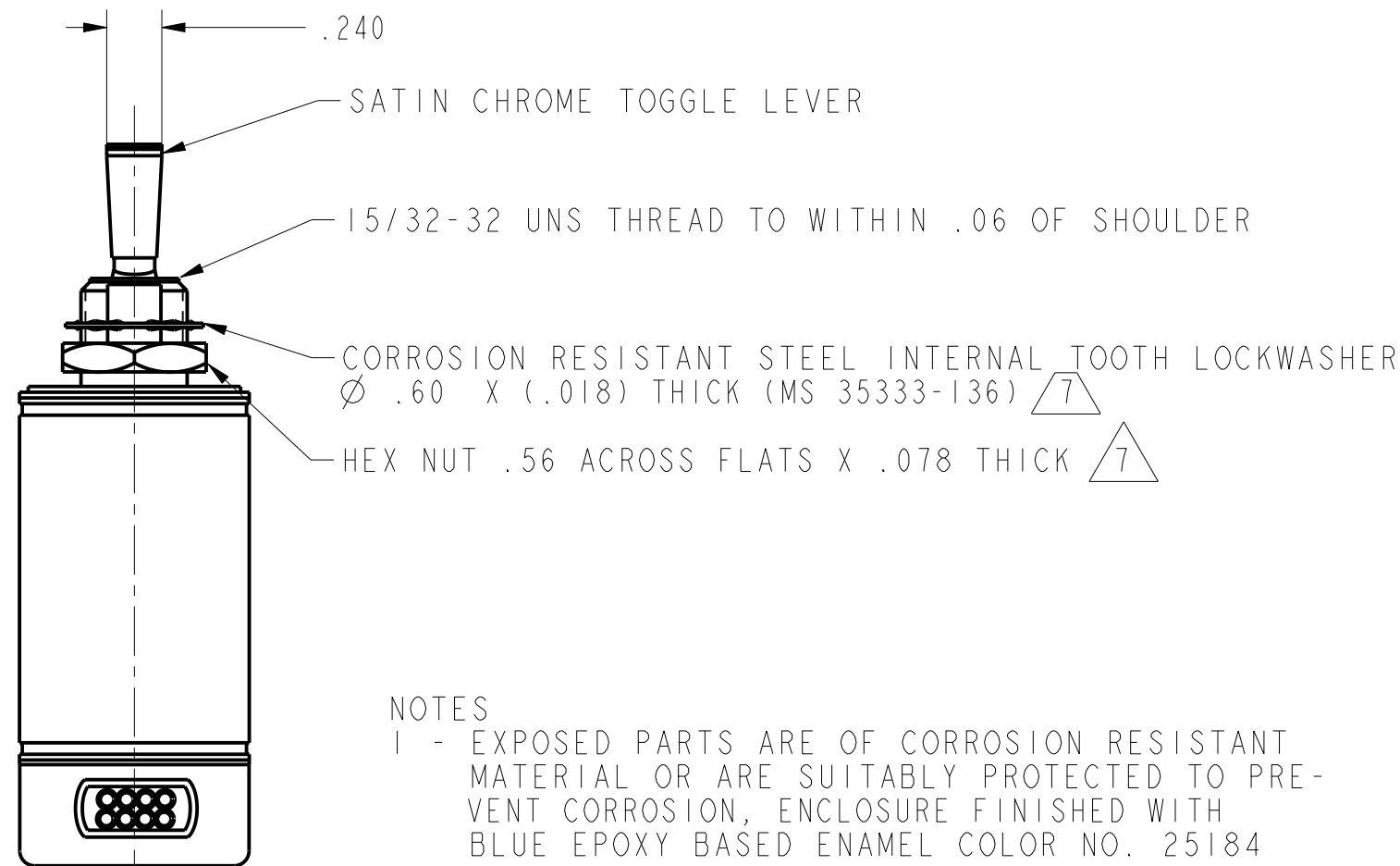
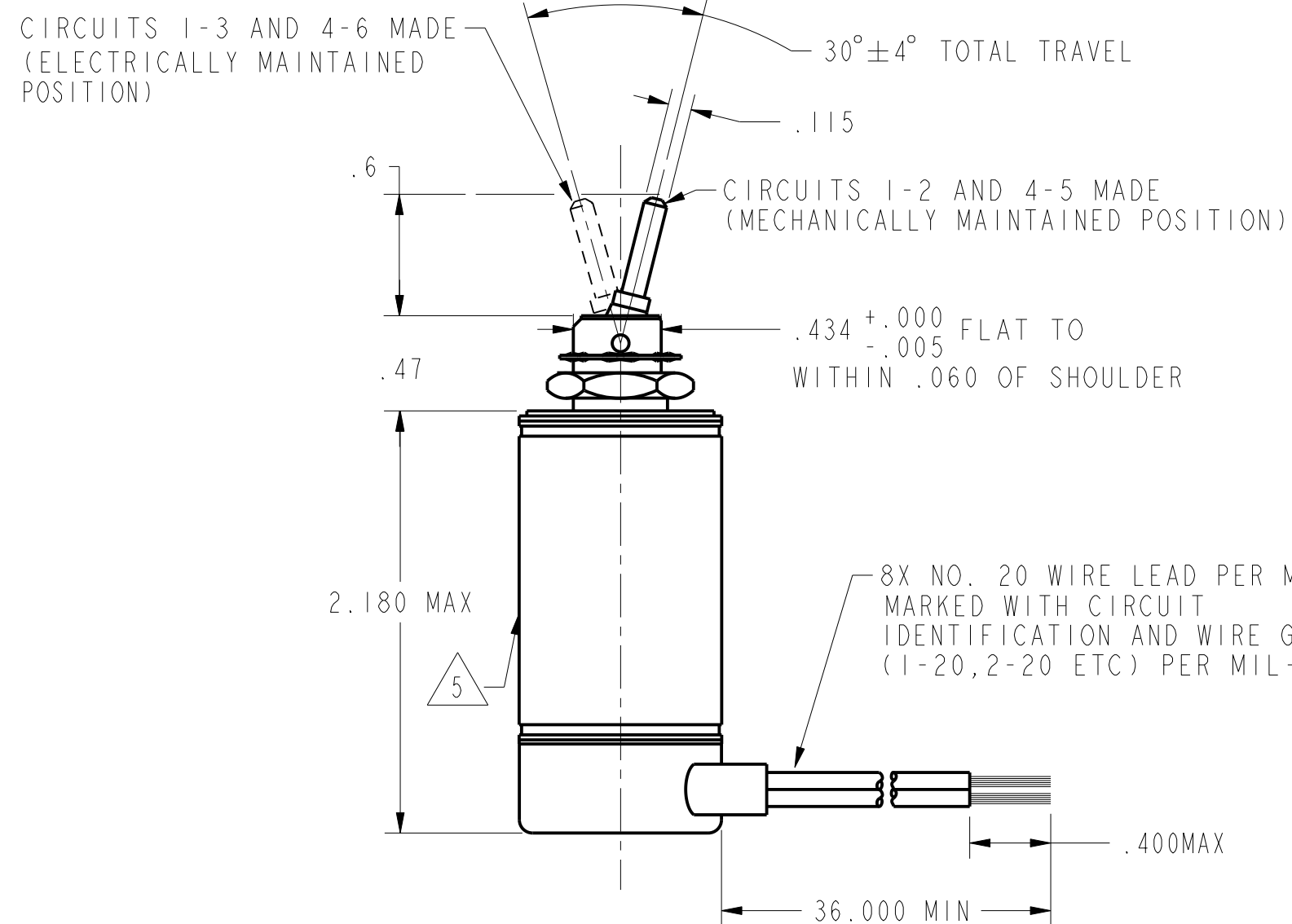
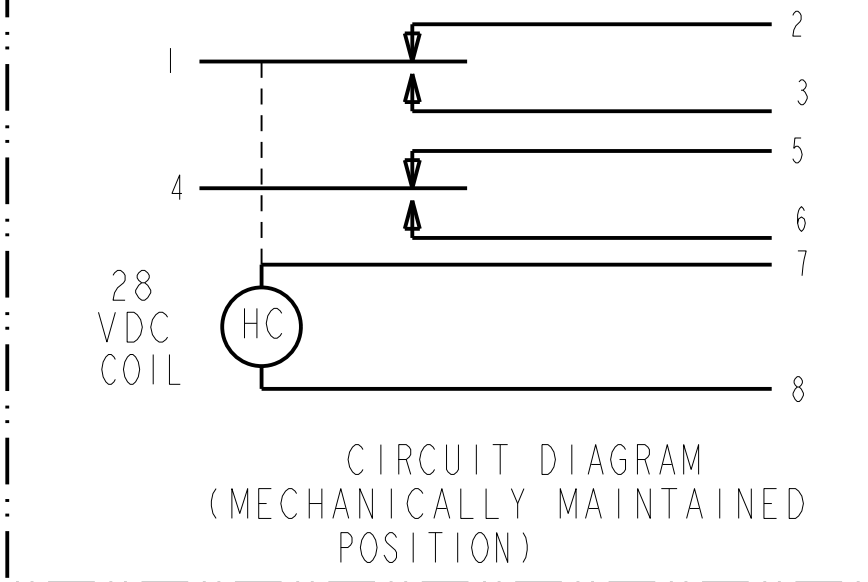
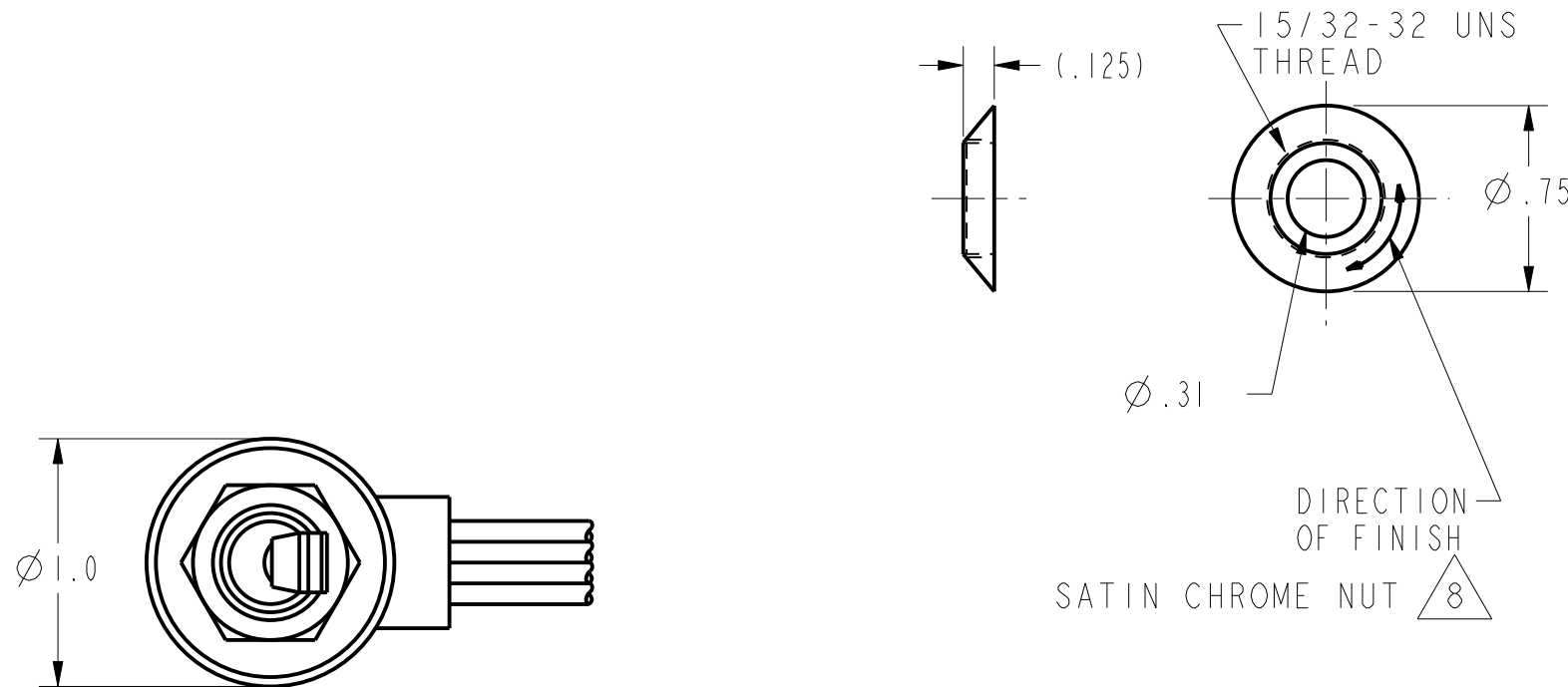

- NOTES
- 1 - EXPOSED PARTS ARE OF CORROSION RESISTANT MATERIAL OR ARE SUITABLY PROTECTED TO PREVENT CORROSION, ENCLOSURE FINISHED WITH BLUE EPOXY BASED ENAMEL COLOR NO. 25184 PER FEDERAL STANDARD 595
  - 2 - SWITCH SEALED PER MIL-S-5594
  - 3 - HOLD IN VOLTAGE: THE MINIMUM SPECIFIED VOLTAGE AT WHICH THE LEVER WILL REMAIN ACTUATED. HOLD IN MAY OCCUR AT A LOWER VALUE. DROP OUT VOLTAGE: THE VOLTAGE RANGE IN WHICH THE LEVER WILL BE RELEASED
  - 4 - CIRCUITS CAN BE TRANSFERRED MANUALLY. ENERGIZING THE COIL WILL NOT CAUSE TRANSFER OF CIRCUITS
  - 5 - CIRCUIT IDENTIFICATION, CATALOG LISTING, FSCM CODE, MICRO SWITCH, FAA-PMA AND DATE CODE IS SHOWN ON SWITCH
  - 6 - SWITCHES DO NOT NECESSARILY OPERATE SIMULTANEOUSLY
  - 7 - HARDWARE MAY BE FURNISHED UNASSEMBLED PER MIL-S-5594
  - 8 - FURNISHED UNASSEMBLED
  - 9 - FOR MANUFACTURING DETAIL SEE ASSEMBLY DRAWING 26ET24-3 FOR FAA-PMA

CHARACTERISTICS	ELECTRICAL DATA
STEADY STATE LIMITS ----- 20-29 VDC	CONTACT ARRANGEMENT 2X S P D T
HOLD IN ----- 15 VDC	RATINGS IN AMPERES
DROP OUT ----- 0-15 VDC	VOLTAGE
OVERRIDE FORCE AT 29VDC ----- 10 LB MAX	SEA LEVEL
OPERATING FORCE ----- 7 LBS MAX	65,000 FT
COIL RESISTANCE ----- 220 OHM MIN	28 VOLTS DC
SOLENOID RATING AT 20°C	

RATINGS IN AMPERES	
VOLTS	AMPERES
28	2.5
24	2.0
20	1.5
16	1.0
12	0.75
8	0.5
4	0.25

DESIGN UNITS: INCH	DRAWN	GJW	30OCT00
TOLERANCES UNLESS NOTED:	CHECK	SAV	30OCT00
NO PLACE	X	±	0.040
ONE PLACE	.X	±	.030
TWO PLACE	.XX	±	.015
THREE PLACE	.XXX	±	.005
FOUR PLACE	.XXXX	±	0.0001
ANGLES	X	±	0

THIS DRAWING COVERS A PROPRIETARY ITEM AND IS THE PROPERTY OF HONEYWELL. THIS DRAWING IS NOT TO BE COPIED OR USED WITHOUT THE PERMISSION OF HONEYWELL.	
INTERPRET PER ANSI Y14.5M 1982 OTHER HONEYWELL ENGINEERING STANDARDS MAY APPLY	SCALE FULL
Pro/ENGINEER	2D

<b>Honeywell</b>	
TITLE <b>SWITCH-TOGGLE (MAGNETIC HOLD-IN)</b>	
SIZE <b>C</b>	TYPE <b>I</b>
DRAWING NAME <b>26ET24-3</b>	REV <b>11</b>
WEIGHT: 8.2 OZ MAX	SHEET 1 OF 1