

MINIATURE CERAMIC SMD CRYSTAL



ABM12

1.6 x 1.2 x 0.45mm

ABM12

RoHS/RoHS II Compliant

Moisture Sensitivity Level (MSL) – This product is Hermetically Sealed and not Moisture Sensitive - MSL = N/A: Not Applicable

FEATURES:

- Suitable for RoHS reflow profile
- Available tight tolerance and stability
- Electron beam sealed ceramic package assures high precision and reliability

APPLICATIONS:

- Blue-tooth, Wireless applications
- Computers, Modems, Microprocessors
- Communication, Test equipment
- High density applications
- PCMCIA
- Portable radios and MP3 players

STANDARD SPECIFICATIONS:

Parameters	Minimum	Typical	Maximum	Units	Notes
Frequency Range	24.000		80.000	MHz	
Standard Frequencies	26.000, 32.000 and 36.000MHz				(Contact Abracon for other frequencies)
Operation Mode	Fundamental				
Operating Temperature	-10		+50	°C	Option "blank," See options
Storage Temperature	-40		+85	°C	
Frequency Tolerance @+25°C	-50		+50	ppm	Option "blank," See options
Frequency Stability over the Operating Temperature (ref. to +25°C)	-50		+50	ppm	Option "blank," See options
Equivalent series resistance (R1)			200	Ω	24.000~39.999MHz
			100		40.000~80.000 MHz
Shunt capacitance (C0)			5	pF	
Load capacitance (CL)	8			pF	Option "blank," See options
Drive Level		10	100	μW	
Aging	-5		+5	ppm	@25°C±3°C First year
Insulation Resistance	500			MΩ	@ 100Vdc ± 15V

OPTIONS & PART IDENTIFICATION: (Left blank if standard)

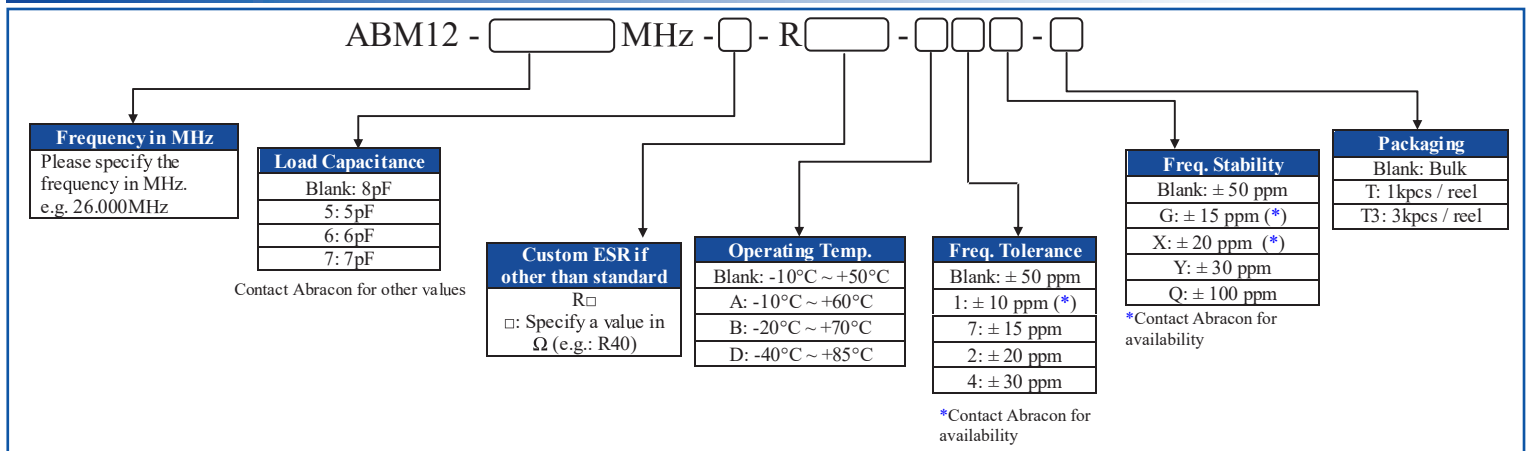

MINIATURE CERAMIC SMD CRYSTAL



1.6 x 1.2 x 0.45mm

ABM12

RoHS/RoHS II Compliant

OUTLINE DRAWING:

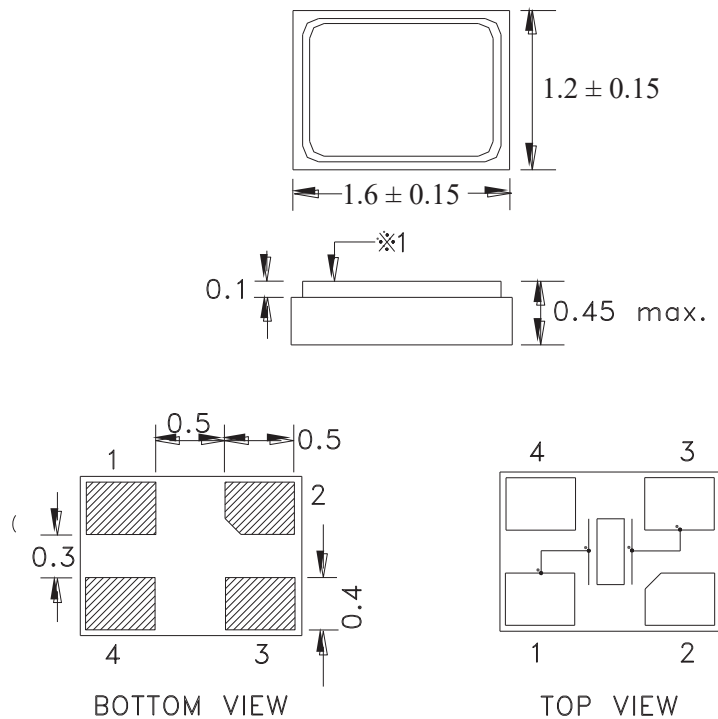

Recommended land pattern

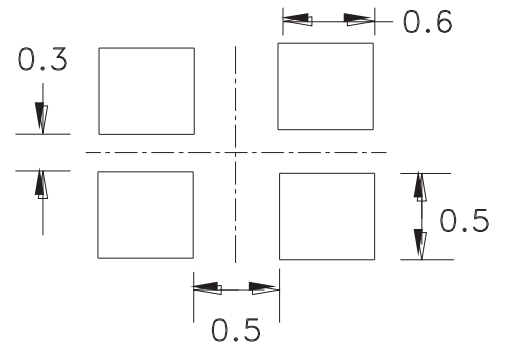

Pin 2 is connected to the metal lid (*1).
(Please connect to GND)

Note 1: Due to material availability, the outline and finish color of the component lid may vary. This variation in no way affects the electrical performance of the product.

Note 2: Due to material availability the chamfer could be located on pin #1, 2 or 4. Be advised that the chamfer location has no impact on the electrical performance of the device.

Dimensions: mm

MINIATURE CERAMIC SMD CRYSTAL



ABM12

1.6 x 1.2 x 0.45mm

ABM12

Pb RoHS/RoHS II Compliant

➤ Tghny 'Rt qhkg']LGF GE 'L/UVF /242_

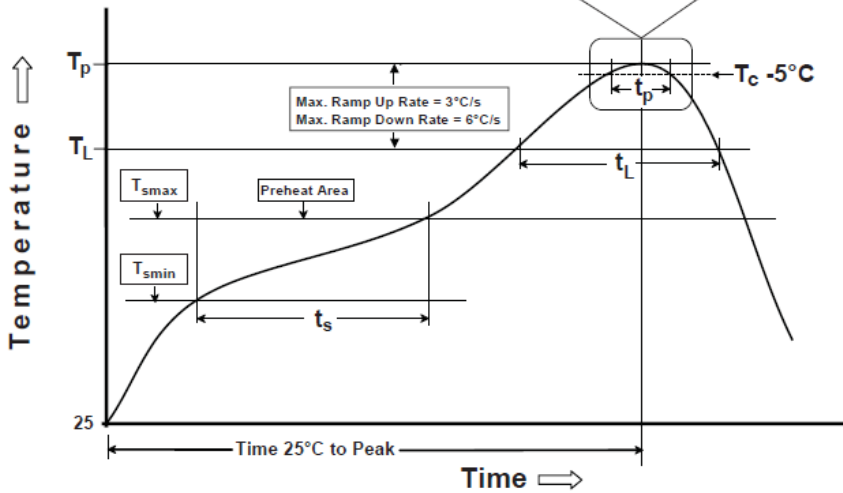
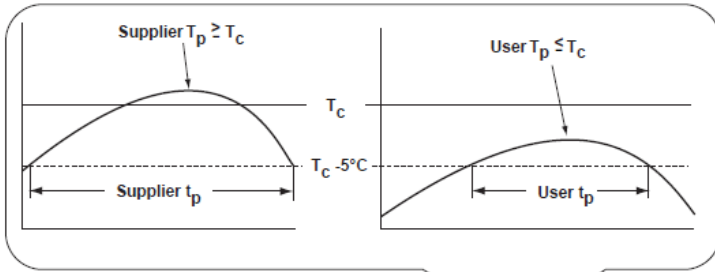

Vcdng'3''

Up/Rd'Gwgeve'Rt qegui'
Er uñhlecvkqp'Vgo rgt cwt gu'Ve+'

Rcenci g'' Vj lempgu'	Xqno g'b o 5'' >572''	Xqno g'b o 5'' ≥572
>40'o o "	457'Æ''	442'Æ''
≥40'o o	442'Æ''	442'Æ''

Vcdng'4''

Rd/Ht gg'Rt qegui'
Er uñhlecvkqp'Vgo rgt cwt gu'Ve+'

Rcenci g'' Vj lempgu'	Xqno g'b o 5'' >572''	Xqno g'b o 5'' 572/4222	Xqno g'b o 5'' >4222
>30'o o "	482'Æ''	482'Æ''	482'Æ''
30'o o "/40'o o "	482'Æ''	472'Æ''	467'Æ''
>40'o o	472'Æ''	467'Æ''	467'Æ''

Rt qhkg'Hgc vwt g''	Up/Rd'Gwgeve'' 'Cugo drf ''	Rd/Ht gg'' Cugo drf ''
Rt gj gcv'Tuqeni'		
"Vgo r gtcwtg'o lpo wo "Vuo lp+''	322'Æ''	372'Æ''
"Vgo r gtcwtg'o czko wo "Vuo cz+''	372'Æ''	422'Æ''
"Vlo g'Vuo lp'Vq'Vuo cz+''Vr+''	82''/342'uge0'	82''/342'uge0'
Cxgtci g'tco r/wr 'tevg'Vuo cz'Vq'Vr+''	5'Æ hge0'o cz''	5'Æ hge0'o cz''
Nls wkf qvu'vgo r gtcwtg'VN+''	3: 5'Æ''	439'Æ''
Vlo g'cv'is wkf qvu'VN+''	82''/372'uge0'	82''/372'uge0'
Rgcnir cenci g'dqf { 'vgo r gtcwtg'VR+''	ugg'Vcdng'3''	ugg'Vcdng'4''
Vlo g'Ve+, 'y kj lp'7'Æ'qh'v'g'ur gelhgf "encuñhlecvkqp'vgo r gtcwtg'VE+''	42'uge0'	52'uge0'
Tco r/fqy p'tevg'Vr'Vq'Vuo cz+''	8'Æ hge0'o cz''	8'Æ hge0'o cz''
Vlo g'47'Æ'Vq'r gcnivgo r gtcwtg''	8'o lp0'o cz''	: 'o lp0'o cz''
Tghny 'e{ engu'	4'o cz''	4'o cz''

• Vqrgtcepg'ht' gcnir tqhkg'vgo r gtcwtg'Ve+kuT'ghpgf'cu'w'r r'igt'o lpo wo 'cpf'c'vugt'o czko wo 0
 .. Vqrgtcepg'ht' 'lo g'cv'r gcnir tqhkg'vgo r gtcwtg'Ve+kuT'ghpgf'cu'w'r r'igt'o lpo wo 'cpf'c'vugt'o czko wo 0

MINIATURE CERAMIC SMD CRYSTAL



ABM12

1.6 x 1.2 x 0.45mm

ABM12

RoHS/RoHS II Compliant

TAPE & REEL:

Option "-T": Tape and reel (1,000pcs/reel)

Option "-T3": Tape and reel (3,000pcs/reel)

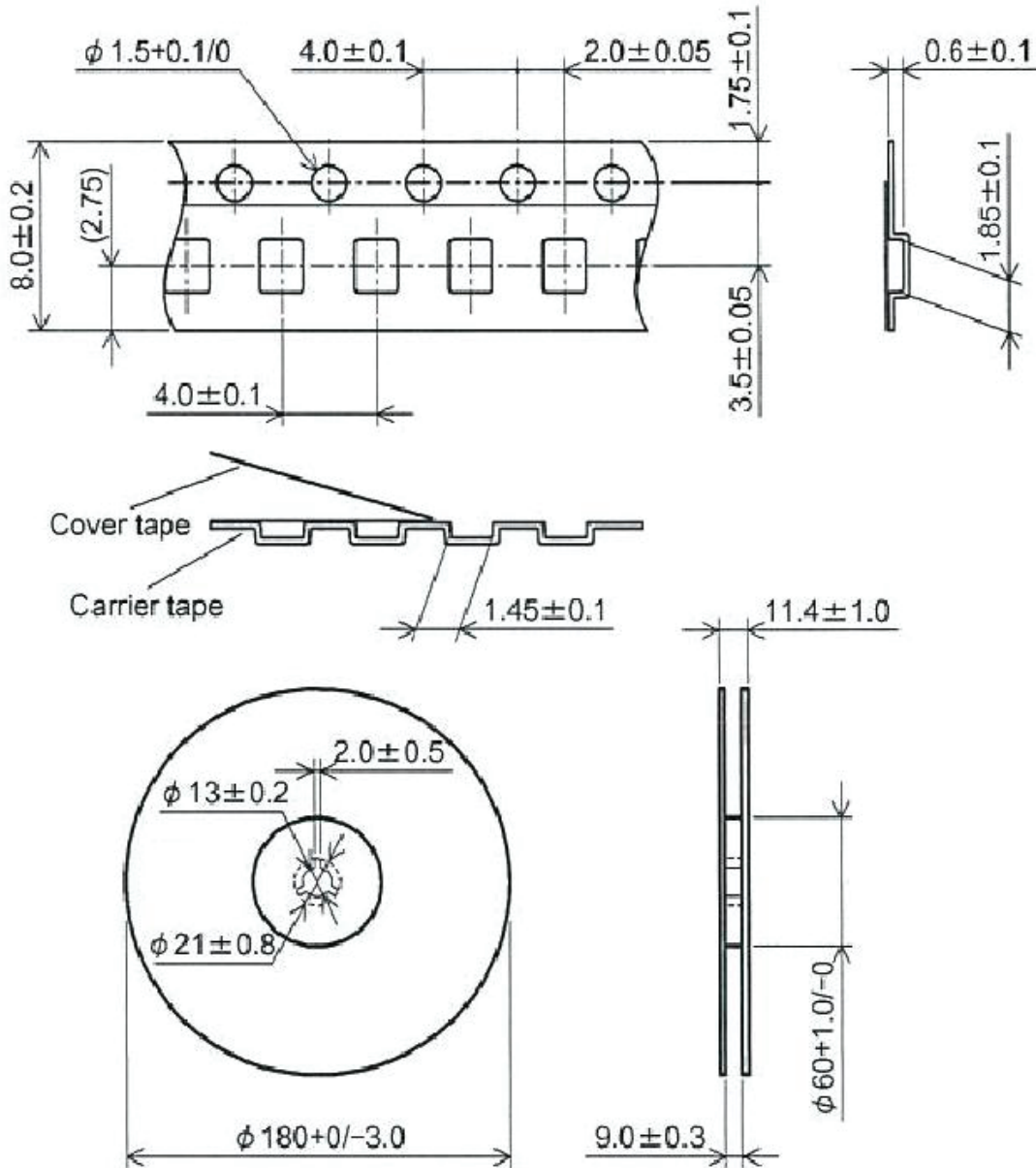

Dimensions: mm