

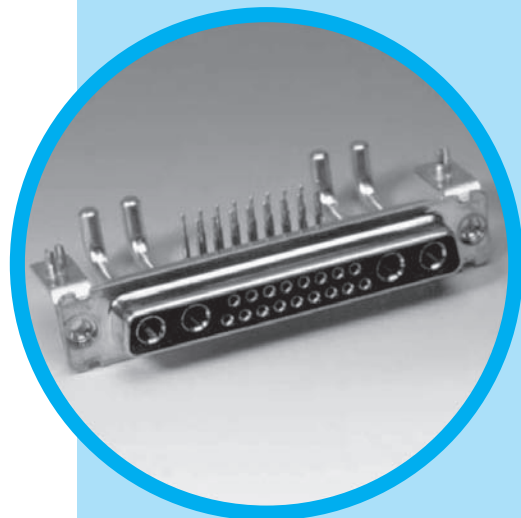

TW

Hybrid D'Sub series



CONTENT

Specifications

- Connectors according to: MIL C24308 - NFC93425 - HE507

Materials and plating		Electrical Data	
Shells	Steel-Tin plating	Current rating	
Insulators	High temperature black thermoplastic	Signal contacts	7.5 A. with 10 A. peak
Signal contacts	Female: machined bronze	Power contacts	
Material	Male: machined brass	PCB terminations	10 to 40 A.
Plating finish	15µ" Au over 79µ" Ni min.	Solder cup terminations	10 to 40 A.
Or	30µ" Au over 79µ" Ni min.	Crimp terminations	10 to 40 A.
Shielded contacts	Female: machined bronze	Shielded contacts	0.5 A.
Material	Male: machined brass	Voltage rating	
Plating		Signal and power contacts	300 V.R.M.S. at 50 Hz
Inner conductor	15µ" Au or 30µ" Au over 79µ" Ni	Shielded contacts	150 V.R.M.S. at 50 Hz
Outer ring	Flash Au over 79µ" Ni	Shielded contacts	
Terminations	Tinned	Frequency range	0-1 GHz
Except solder cup and crimp terminations	gold flash	Attenuation	0.2dB
Power contacts	Female: machined bronze	V. S. W. R.	1.4(+0.04/GHz)
Material	Male: machined brass	Characteristic impedance	50 Ohms
Plating		Dielectric withstanding voltage	≥ 1000 V.R.M.S. at 50Hz
Contacts	15µ" Au or 30µ" Au over 79µ" Ni	Insulation resistance	≥ 5000 M Ohms at 500 VDC
Terminations	Tinned	Contact resistance	≤ 5m Ohms
Except solder cup and crimp terminations	gold flash	Shell resistance (electrical grounding)	≤ 1m Ohm
Brackets	Steel-Tin plating		
Front jackscrews	Brass-Tin plating		
Rear clinch nuts	Brass-Tin plating		
Boardlocks	Bronze-Tin plating		
Stand-off	Brass-Tin plating		

Climatic Data		Mechanical data	
Operating temperature	-55°C + 155°C (with peak 180°C)	Shells	With or without dimples
Damp heat	56 days (40°C - 95% HR)	Contact retention force in dielectric material	> 40N
Salt spray	48 hours	Maximum mating and unmating force	
		With dimples	E size = 70 N A size = 80 N B size = 100 N C size = 150 N D size = 180 N
		Without dimples	E size = 30 N A size = 50 N B size = 80 N C size = 120 N D size = 160 N
		Compatible with process	
		IR - Air convectioned	260° for 20 s.
		Resistance to solder iron heat	260°C for 30 s.
		Mating cycles	≥ 200 (class II) or 500 (class I)



DESCRIPTION

Amphenol D'Sub TW Hybrid Series permits a mix of contacts including signal, power, shielded, high voltage and fiber optics in the same housing with different contacts arrangements.

This economic series was first developed from our military series, and has improved features:

- new contacts
- new high temperature black thermoplastic insert
- PCB configurations come preloaded with fixed contacts and brackets.

These connectors are supplied with screw machined contacts fixed in the insulator.

A complete range of housings are also available for cable application.

A full series of arrangements compatible with reflow process

APPLICATIONS

- Commercial
- Medical
- Industrial
- Telecom
- Any application requiring optimization of space



Amphenol

TW / E1

Shell and contacts plating

CLASS II

0.4µm (15µ") Au contacts gold plating
200 mating cycles

Types	Shells and plating
77 TW	Tin plated shell <i>*Male and female</i>
717 TW	Tin plated shell with dimples <i>Male only</i>



















CLASS I

0.76µm (30µ") Au contacts gold plating
500 mating cycles

Types	Shells and plating
177 TW	Tin plated shell <i>*Male and female</i>
777 TW	Tin plated shell with dimples <i>Male only</i>

Housing arrangements

Male front view

Arrangement Shell size	 5W1 E	 7W2 A	 11W1 A
Arrangement Shell size	 3W3 A	 5W5 B	 9W4 B
Arrangement Shell size	 13W3 B	 17W2 B	 21W1 B
Arrangement Shell size	 27W2 C	 13W6 C	 17W5 C
Arrangement Shell size	 21W4 C	 8W8 C	 25W3 C
Arrangement Shell size	 24W7 D	 36W4 D	 43W2 D

Additional arrangements

Arrangement..... Shell Size.....	 2W2 E	 P2W2 E (polarized)	 P3W3 A (polarized)
-------------------------------------	---	--	--

Shell size dimensions

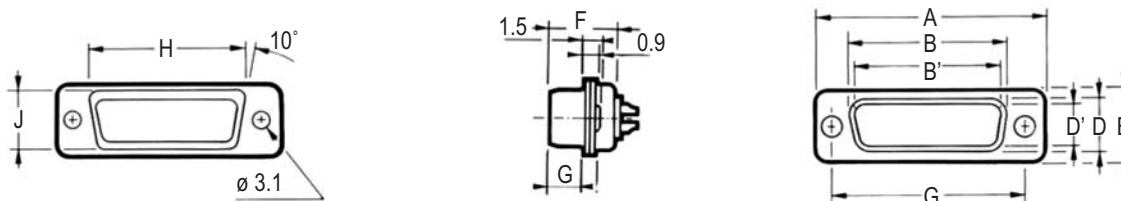

Shell size	Contact P: Pin S: Socket	A ±0.25 (±.010)	B 0/-0.20 (0/- .008)	B' +0.20/0 (+.008/0)	C ±0.10 (±.004)	D 0/-0.25 (0/- .010)	D' +0.25/0 (+.010/0)	E ±0.20 (±.008)	F +0.05/-0.20 (+.002/- .008)	F' +0.10/-0.20 (+.004/- .008)	G +0.10/-0.20 (+.004/- .008)	G' ±0.10 (±.004)	H +0.10/-0.40 (+.004/- .016)	J 0/-0.50 (0/- .020)
E	P	30.7 (1.209")		16.8 (.661")	25.0 (.984")		8.2 (.323")	12.4 (.488")		10.9 (.429")		5.9 (.232")	19.4 (.764")	11.0 (.433")
	S		16.4 (.646")			8.0 (.315")			11.1 (.437)		6.2 (.244")			
A	P	39.0 (1.535")		25.1 (.988")	33.3 (1.311")		8.2 (.323")	12.4 (.488")		10.9 (.429")		5.9 (.232")	27.7 (1.091")	11.0 (.433")
	S		24.8 (.976")			8.0 (.315")			11.1 (.437)		6.2 (.244")			
B	P	52.9 (2.083")		38.8 (1.528")	47.0 (1.850")		8.2 (.323")	12.4 (.488")		11.0 (.433")		5.8 (.228")	41.4 (1.630")	11.0 (.433")
	S		38.5 (1.513")			8.0 (.315")			11.1 (.437)		6.2 (.244")			
C	P	69.2 (2.724")		55.3 (2.177")	63.5 (2.500")		8.2 (.323")	12.4 (.488")		11.0 (.433")		5.8 (.228")	57.9 (2.280")	11.0 (.433")
	S		54.9 (2.161")			8.0 (.315")			11.1 (.437)		6.2 (.244")			
D	P	66.8 (2.630")		52.7 (2.075")	61.1 (2.406")		11.0 (.433")	15.2 (.598")		11.0 (.433")		5.8 (.228")	55.5 (2.185")	13.8 (.543")
	S		52.5 (2.067")			10.9 (.429")			11.1 (.437)		6.2 (.244")			

Panel cutouts

Optimal cutout for rear mounting

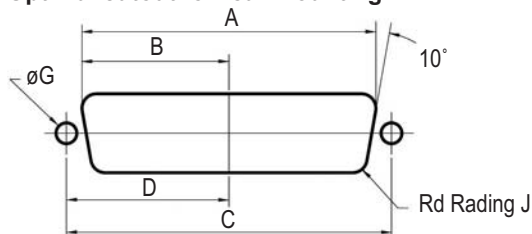

Standard cutout

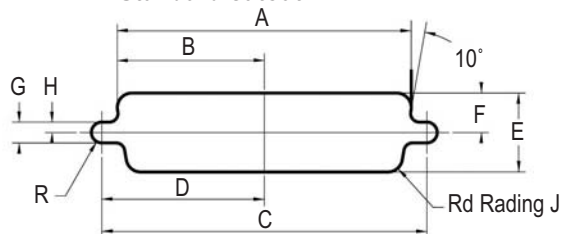

Shell size	Mounting method	A ±0.20 (±.008)	B ±0.20 (±.008)	C ±0.20 (±.008)	D ±0.20 (±.008)	E ±0.20 (±.008)	F ±0.20 (±.008)	G ±0.20 (±.008)	H ±0.20 (±.008)	J ±0.20 (±.008)
E	Front	22.2 (.874")	11.1 (.437")	25.0 (.984")	12.5 (.492")	13.0 (.512")	6.5 (.256")	3.0 (.118")	1.5 (.059")	2.1 (.083")
	Rear	20.5 (.807")	10.2 (.402")			11.4 (.449")	5.7 (.224")			3.4 (.134")
A	Front	30.5 (1.201")	15.3 (.602")	33.3 (1.311")	16.7 (.657")	13.0 (.512")	6.5 (.256")	3.0 (.118")	1.5 (.059")	2.1 (.083")
	Rear	28.8 (1.134")	14.4 (.567")			11.4 (.449")	5.7 (.224")			3.4 (.134")
B	Front	44.3 (1.744")	22.1 (.870")	47.0 (1.850")	23.5 (.925")	13.0 (.512")	6.5 (.256")	3.0 (.118")	1.5 (.059")	2.1 (.083")
	Rear	42.5 (1.673")	21.3 (.839")			11.4 (.449")	5.7 (.224")			3.4 (.134")
C	Front	60.7 (2.390")	30.4 (1.197")	63.5 (2.500")	31.7 (1.248")	13.0 (.512")	6.5 (.256")	3.0 (.118")	1.5 (.059")	2.1 (.083")
	Rear	59.1 (2.327")	29.5 (1.161")			11.4 (.449")	5.7 (.224")			3.4 (.134")
D	Front	58.3 (2.295")	29.2 (1.150")	61.1 (2.406")	30.6 (1.205")	15.8 (.622")	7.9 (.311")	3.0 (.118")	1.5 (.059")	2.1 (.083")
	Rear	56.3 (2.217")	28.2 (1.110")			14.1 (.555")	7.1 (.280")			3.4 (.134")

Straight connector footprint

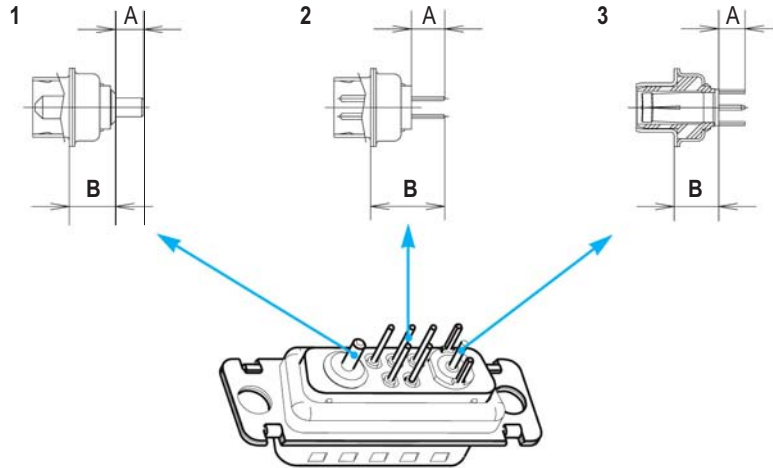

Signal tail 0.6 mm Dia. (.024")
 1.6 mm (.063")PCB
 For other PCB thickness: consult factory.

Description		Dimensions	
		a	b
Power 3.2mm(.126") tail dia	1	4.80 mm (.189")	7.2 mm (.283")
Power 2.0mm(.078") tail dia	1	4.80 mm (.189")	7.2 mm (.283")
Shielded	3	4.00 mm (.157")	7.2 mm (.283")
Signal	2	5.30 mm (.209")	11.50 mm (.453")

Straight contact combinations

Arrangement with signal contacts

See above dimensions	Size 8 and 20 Contacts
↓	
P 3SY	Power 3.2 mm DIA. (.126") (20 to 40 A) and signal
P 2SY	Power 2 mm DIA. (.078") (10 to 20 A) and signal
CSY	Shielded and signal
SY	Signal only
No reference	Signal (Size 20) with solder cup terminations <i>Housing preloaded with contacts</i>

Arrangement without signal contacts 2W2 - 3W3 - 5W5 - 8W8

See above dimensions	Size 8 Contacts
↓	
P 3Y	Power only 3.2 mm DIA. (.126") (20 to 40 A)
P 2Y	Power only 2 mm DIA. (.078") (10 to 20 A)
CY	Shielded only

Right angle connector footprint

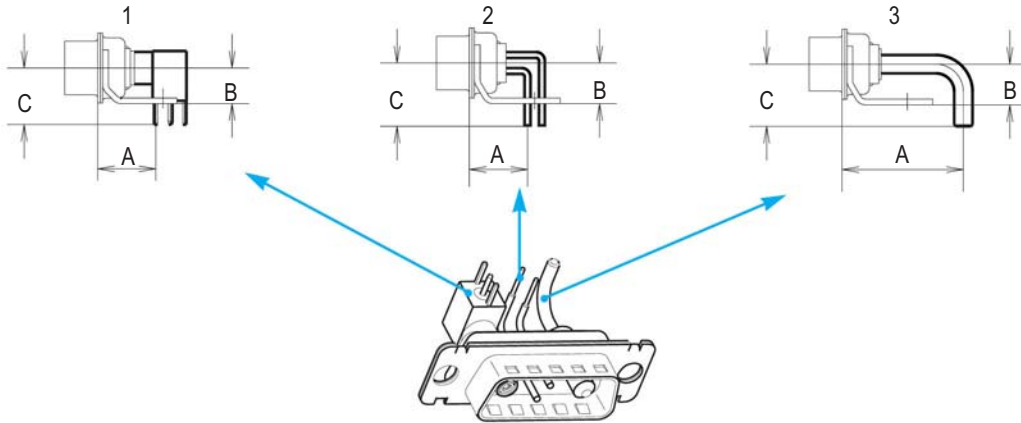

Signal tail 0.6 mm Dia. (.0236")
 1.6 mm (.063") PCB
 For other PCB thickness: consult factory.

Description	Europe			Mix			MIL			
	a	b	c	a	b	c	a	b	c	
Shielded	1	-	-	-	-	-	-	-	-	
Signal	2	10.30mm (.406")	7.20mm (.283")	11.20mm (.441")	10.30mm (.406")	6.30mm (.248")	9.50mm (.374")	8.10mm (.319")	6.30mm (.248")	9.50mm (.374")
Power 2.0mm(.078") tail dia	3	11.57mm (.456")	7.20mm (.283")	10.50mm (.413")	11.57mm (.456")	6.30mm (.248")	9.50mm (.374")	9.52mm (.375")	6.30mm (.248")	9.50mm (.374")
Power 3.2mm(.126") tail dia	3	21.46mm (.845")	7.20mm (.283")	10.50mm (.413")	21.46mm (.845")	6.30mm (.248")	9.50mm (.374")	21.46mm (.845")	6.30mm (.248")	9.50mm (.374")

Note: above dimensions correspond to sizes E to C. Consult factory for D sizes.
 Connector comes equipped with contacts and brackets.

Right angle contacts combinations

Arrangement with signal contacts

European footprint	Mixed footprint	MIL (U.S.) footprint	Size 8 and 20 Contacts
EP3SV	HP3SV	MP3SV	Power 3.2 mm DIA. (.126") (20 to 40 A) and signal
EP2SV	HP2SV	MP2SV	Power 2 mm DIA. (.078") (10 to 20 A) and signal
-	HCSV	MCSV	Shielded and signal
ESV	HSV	MSV	Signal only

Arrangement without signal contacts 2W2 - 3W3 - 5W5 - 8W8

European footprint	Mixed footprint	MIL (U.S.) footprint	Size 8 contacts only
EP3V	HP3V	MP3V	Power only 3.2 mm DIA. (.126") (20 to 40 A)
EP2V	HP2V	MP2V	Power only 2.0 mm DIA. (.078") (10 to 20 A)
-	HCV	MCV	Shielded only

Mounting options

Right angle version

Connectors come equipped with metal brackets

BLANK: 3.10mm (.122") dia mounting hole

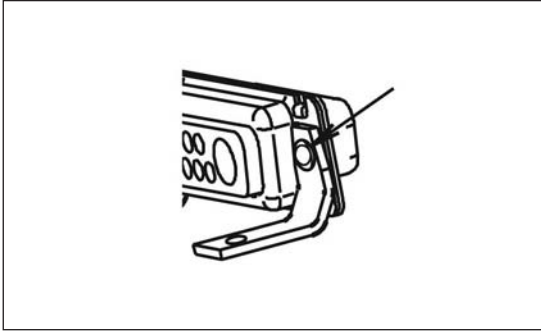

RM6: metal brackets + boardlock

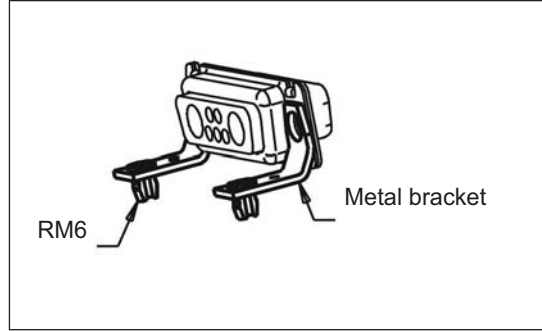

Straight version

BLANK: 3.10mm (.122") dia mounting hole

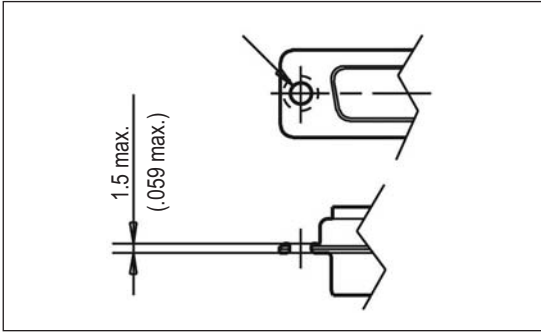

RM54: 4-40 threaded

RM53: M3 threaded

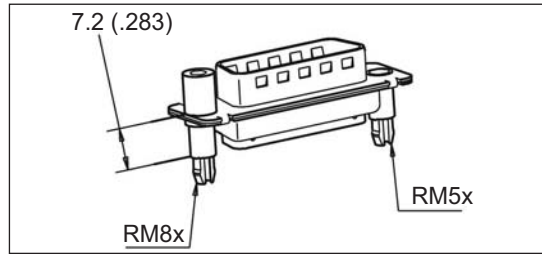

RM84: 4-40 threaded

RM83: M3 threaded

A514: blind mating system

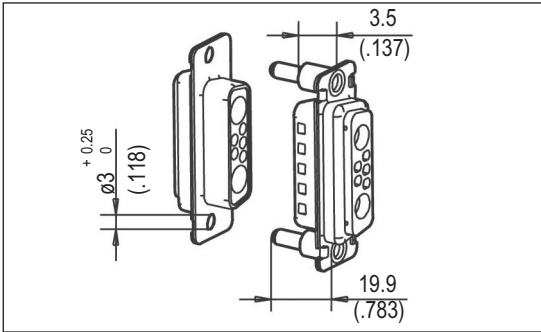

FM: float mounting system

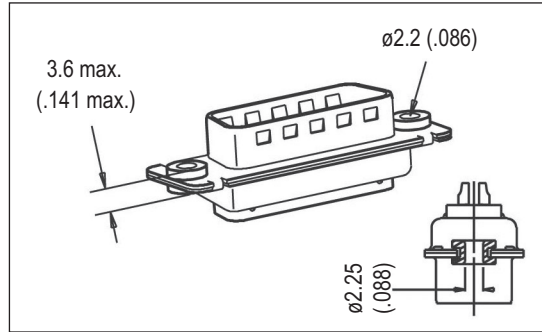

Straight and right angle version

4R: 4-40 rear nut

3R: M3 rear nut

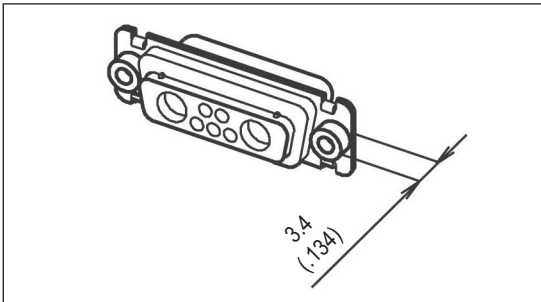

4F: 4-40 front female screwlock

3F: M3 front female screwlock

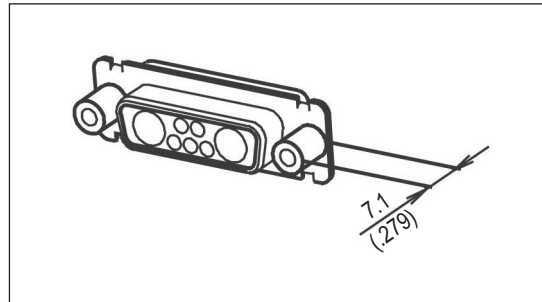

High power contacts

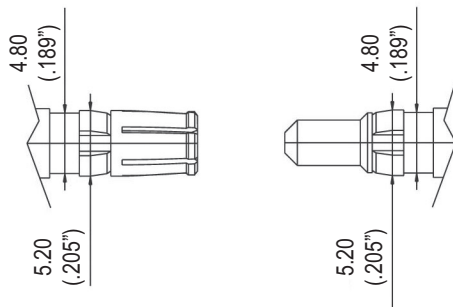

Solder cup version

Technical drawings of solder cup version contacts. The left drawing shows a side view with a diameter of 22 (.866) and diameters øA and øB. The right drawing shows a top view with a diameter of 22 (.866) and diameters øA and øB. A third drawing shows a side view of the solder cup with a height of 16 (.622).

Plug	P/N Socket	Current	Dimensions	
			A mm (inch)	B mm (inch)
L 17DM 53745-8	L 17DM 53744-7	10 to 20 Amp.	1.80 (.071")	2.55 (.100")
L 17DM 53745-7	L 17DM 53744-6	20 to 30 Amp.	2.80 (.110")	3.70 (.145")
L 17DM 53745-1	L 17DM 53744-1	30 to 40 Amp.	4.80 (.189")	5.60 (.220")

Trim dimensions: 7.5 mm (.295")

Crimp version

Technical drawings of crimp version contacts. The left drawing shows a side view with a diameter of 22 (.866) and diameters øA and øB. The right drawing shows a top view with a diameter of 22 (.866) and diameters øA and øB. A third drawing shows a side view of the crimp with a height of 16 (.622).

Plug	P/N Socket	Current	Dimensions	
			A mm (inch)	B mm (inch)
L 17DM 53745-208	L 17DM 53744-207	10 to 20 Amp.	1.80 (.071")	2.55 (.100")
L 17DM 53745-207	L 17DM 53744-206	20 to 30 Amp.	2.80 (.110")	3.70 (.145")
L 17DM 53745-201	L 17DM 53744-201	30 to 40 Amp.	4.80 (.189")	5.60 (.220")

Trim dimensions: 7.5 mm (.295")

**Crimping tool for all sizes
L17D479SP**



Extraction tool for sizes 8 cts



Straight shielded contacts

Crimp ferrule and inner solder

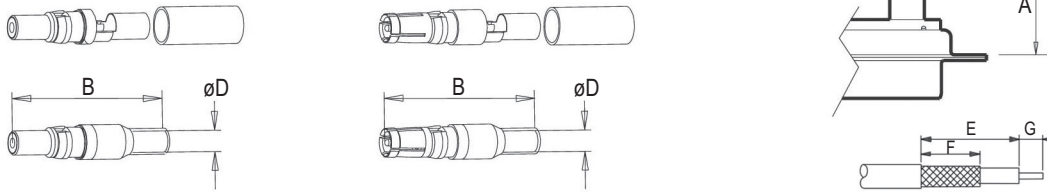

Type	P/N	Dimensions (inch)			Cable - RG	Trim dimensions (inch)		
		A Max	B	D		E	F	G
plug	L17DM 53740	18.8 (740")	23.6 (.929")	1.0 (.039")	178 B/U	7.9 (.311")	6.3 (.248")	2 (.078")
plug	L17DM 53740-1	18.8 (740")	23.6 (.929")	1.7 (.066")	179 B/U 316 B/U	7.9 (.311")	6.3 (.248")	2 (.078")
plug	L17DM 53740-3	21.5 (846")	23.6 (.929")	2.8 (.110")	180 B/U	9.5 (.374")	7.9 (.311")	2 (.078")
plug	L17DM 53740-5	21.5 (846")	23.6 (.929")	3.2 (.126")	58 C/U	9.5 (.374")	7.9 (.311")	2 (.078")
socket	L17DM 53742	18.8 (740")	23.6 (.929")	1.0 (.039")	178 B/U	7.9 (.311")	6.3 (.248")	2 (.078")
socket	L17DM 53742-1	18.8 (740")	23.6 (.929")	1.7 (.066")	179 B/U 316 B/U	7.9 (.311")	6.3 (.248")	2 (.078")
socket	L17DM 53742-3	21.5 (846")	23.6 (.929")	2.8 (.110")	180 B/U	9.5 (.374")	7.9 (.311")	2 (.078")
socket	L17DM 53742-5	21.5 (846")	23.6 (.929")	3.2 (.126")	58 C/U	9.5 (.374")	7.9 (.311")	2 (.078")

Solder ferrule and inner solder

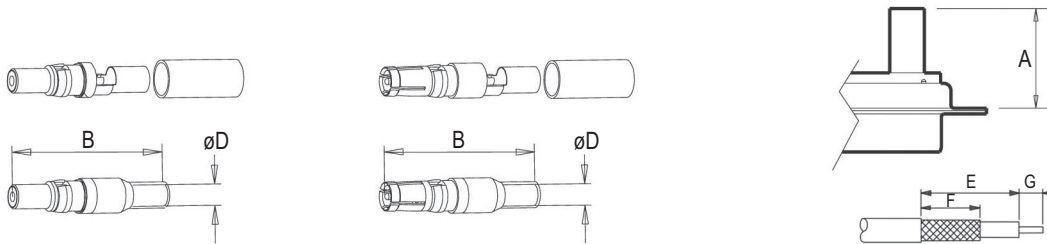

Type	P/N	Dimensions (inch)			Cable - RG	Trim dimensions (inch)		
		A Max	B	D		E	F	G
short plug	L17DM 53740-5000	17.0 (669")	21.8 (.858")	1.0 (.039")	178 B/U	7.9 (.311")	6.3 (.248")	2 (.078")
plug	L17DM 53740-5001	18.8 (740")	23.6 (.929")	1.7 (.066")	179 B/U 316 B/U	7.9 (.311")	6.3 (.248")	2 (.078")
plug	L17DM 53740-5002	21.5 (846")	26.3 (1.035")	2.8 (.110")	180 B/U	9.5 (.374")	7.9 (.311")	2 (.078")
plug	L17DM 53740-5005	21.5 (846")	26.3 (1.035")	3.2 (.126")	58 C/U	9.5 (.374")	7.9 (.311")	2 (.078")
plug	L17DM 53740-5008	18.8 (740")	23.6 (.929")	1.0 (.039")	178 B/U	7.9 (.311")	6.3 (.248")	2 (.078")
short socket	L17DM 53742-5000	17.0 (669")	21.8 (.858")	1.0 (.039")	178 B/U	7.9 (.311")	6.3 (.248")	2 (.078")
socket	L17DM 53742-5001	18.8 (740")	23.6 (.929")	1.7 (.066")	179 B/U 316 B/U	7.9 (.311")	6.3 (.248")	2 (.078")
socket	L17DM 53742-5002	21.5 (846")	26.3 (1.035")	2.8 (.110")	180 B/U	9.5 (.374")	7.9 (.311")	2 (.078")
socket	L17DM 53742-5004	21.5 (846")	26.3 (1.035")	3.2 (.126")	58 C/U	9.5 (.374")	7.9 (.311")	2 (.078")
socket	L17DM 53742-5006	18.8 (740")	23.6 (.929")	1.0 (.039")	178 B/U	7.9 (.311")	6.3 (.248")	2 (.078")

Right angled shielded contact

Crimp ferrule and inner solder

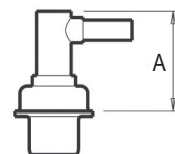
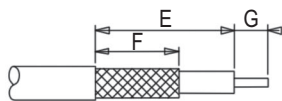
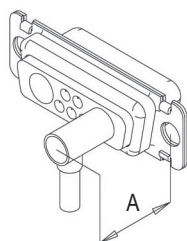

Type	P/N	Dimensions (inch)			Cable - RG	Trim dimensions (inch)		
		A Max	B	D		E	F	G
plug	L17DM 53741	13.5 (.531")	18.6 (.732")	1.0 (.039")	178 B/U	9.5 (.374")	5.9 (.232")	1.6 (.062")
plug	L17DM 53741-1	13.5 (.531")	18.6 (.732")	1.7 (.066")	179 B/U 316 B/U	9.5 (.374")	5.9 (.232")	1.6 (.062")
plug	L17DM 53741-3	13.5 (.531")	18.6 (.732")	2.8 (.110")	180 B/U	10.7 (.421")	7.9 (.311")	2.4 (.094")
plug	L17DM 53741-4	13.5 (.531")	18.6 (.732")	3.2 (.126")	58 C/U	10.7 (.421")	7.9 (.311")	2.4 (.094")
socket	L17DM 53743-2	13.5 (.531")	18.6 (.732")	1.0 (.039")	178 B/U	9.5 (.374")	5.9 (.232")	1.6 (.062")
socket	L17DM 53743-3	13.5 (.531")	18.6 (.732")	1.7 (.066")	179 B/U 316 B/U	9.5 (.374")	5.9 (.232")	1.6 (.062")
socket	L17DM 53743-5	13.5 (.531")	18.6 (.732")	2.8 (.110")	180 B/U	10.7 (.421")	7.9 (.311")	2.4 (.094")
socket	L17DM 53743-6	13.5 (.531")	18.6 (.732")	3.2 (.126")	58 C/U	10.7 (.421")	7.9 (.311")	2.4 (.094")

Ferrule and inner solder

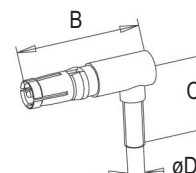
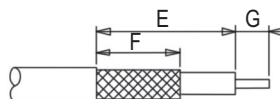
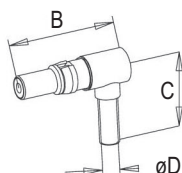

Type	P/N	Dimensions (inch)			Cable - RG	Trim dimensions (inch)		
		A Max	B	D		E	F	G
plug	L17DM 53741-5000	13.5 (.531")	18.6 (.732")	1.0 (.039")	178 B/U	9.5 (.374")	5.9 (.232")	1.6 (.062")
plug	L17DM 53741-5001	13.5 (.531")	18.6 (.732")	1.7 (.066")	179 B/U 316 B/U	9.5 (.374")	5.9 (.232")	1.6 (.062")
plug	L17DM 53741-5003	13.5 (.531")	18.6 (.732")	2.8 (.110")	180 B/U	10.7 (.421")	7.9 (.311")	2.4 (.094")
plug	L17DM 53741-5004	13.5 (.531")	18.6 (.732")	3.2 (.126")	58 C/U	10.7 (.421")	7.9 (.311")	2.4 (.094")
socket	L17DM 53743-5000	13.5 (.531")	18.6 (.732")	1.0 (.039")	178 B/U	9.5 (.374")	5.9 (.232")	1.6 (.062")
socket	L17DM 53743-5001	13.5 (.531")	18.6 (.732")	1.7 (.066")	179 B/U 316 B/U	9.5 (.374")	5.9 (.232")	1.6 (.062")
socket	L17DM 53743-5003	13.5 (.531")	18.6 (.732")	2.8 (.110")	180 B/U	10.7 (.421")	7.9 (.311")	2.4 (.094")
socket	L17DM 53743-5004	13.5 (.531")	18.6 (.732")	3.2 (.126")	58 C/U	10.7 (.421")	7.9 (.311")	2.4 (.094")

Crimping tool

Hand crimp tool

227-0944 (without dies) (M 22 520/5-01)

RG cables	MIL reference	Amphenol P/N	dim. between 2 flat surface	
			cavity A	cavity B
RG 58 C/U	M 22 520/5-05	227 1221-05	5.41	-
RG 178 B/U	M 22 520/5-03	227 1221-03	-	2.67
RG 179 B/U	M 22 520/5-03	227 1221-03	3.25	-
RG 180 B/U	M 22 520/5-05	227 1221-05	-	4.52

Extraction tool

Extraction tool for sizes 8 cts

L17D429SP



Cabling instructions for shielded contacts

Straight crimp shielded contacts:

inner solder contact
outer crimp contact

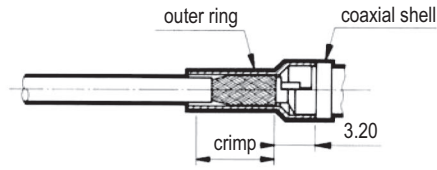
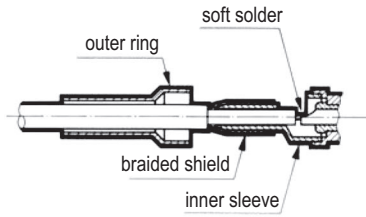

Right angle crimp shielded contacts:

inner solder contact
outer crimp contact

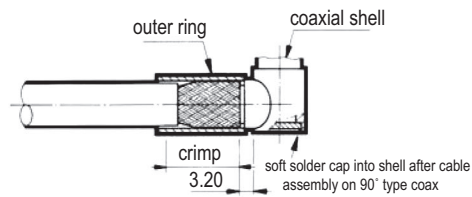
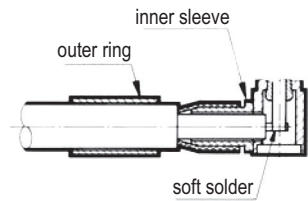

Assembly method

- Slide the outer ring over the cable jacket. Trim the cable according to the recommended dimensions.
- Insert the cable dielectric and the center conductor inside the inner sleeve.
- Solder the central conductor to the shielded center contacts.
- Slide the outer ring towards the inner sleeve and recover the braid.
- Using crimp hand tool equipped with the appropriate dies, crimp in the area defined.

Solder straight shielded contacts:

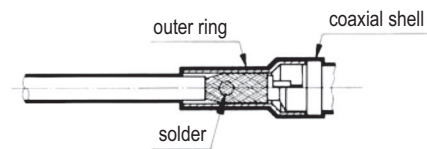
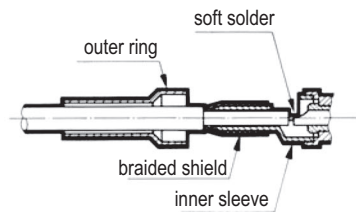

Solder right angle shielded contacts:

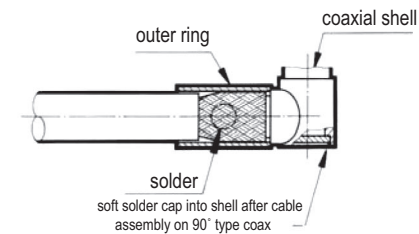
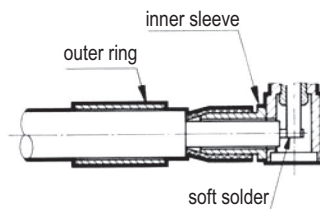

Assembly method

- Slide the outer ring over the cable jacket. Trim the cable according to the recommended dimensions.
- Insert the cable dielectric and the center conductor inside the inner sleeve.
- Solder the central conductor to the shielded center contacts.
- Slide the outer ring towards the inner sleeve and recover the braid.
- Solder by introducing metal through the outer ring hole.

How to build your part number

L

... TW ...

... ..

... ..

... ..

... ..

... ..

RoHS Compliant

Shell & Contact Plating Options

Shell		Contact Plating
Tinned	Tinned & Indents; Plug only	
77	717	0.4μm(15μ") Au
177	777	0.76μm(30μ") Au

Shell Size and Configuration:

E2W2, *P2W2, E5W1, A3W3, *P3W3, A7W2, A11W1, B5W5, B9W4, B13W3, B17W2, B21W1, C8W8, C13W6, C17W5, C21WA4, C25W3, C27W2, D24W7, D36W4, D43W2

Gender:

P: Pin
S: Socket

Terminations:

For Straight PCB and Solder-Cup

BLANK: Solder-cup signal contacts only
P3SY: 20-40 Amp power & signal mix
P2SY: 10-20 Amp power & signal mix
CSY: Coax & signal mix
SY: Signal only
P3Y: 20-40 Amp power only (2W2, 3W3, 5W5, 8W8)
P2Y: 10-20 Amp power only (2W2, 3W3, 5W5, 8W8)
CY: Coax only (2W2, 3W3, 5W5, 8W8)

For Right Angle PCB

MP3SV: US Footprint, 20-40 Amp power & signal mix
MP2SV: US Footprint, 10-20 Amp power & signal mix
MCSV: US Footprint, coax & signal mix
MSV: US Footprint, signal only
MP3V: US Footprint, 20-40 Amp power only (2W2, 3W3, 5W5, 8W8)
MP2V: US Footprint, 10-20 Amp power only (2W2, 3W3, 5W5, 8W8)
MCV: US Footprint, coax only (2W2, 3W3, 5W5, 8W8)
EP3SV: European Footprint, 20-40 Amp power & signal mix
EP2SV: European Footprint, 10-20 Amp power & signal mix
ESV: European Footprint, signal only
EP3V: European Footprint, 20-40 Amp power only (2W2, 3W3, 5W5, 8W8)
EP2V: European Footprint, 10-20 Amp power only (2W2, 3W3, 5W5, 8W8)
HP3SV: Mixed Footprint, 20-40 Amp power & signal mix
HP2SV: Mixed Footprint, 10-20 Amp power & signal mix
HCSV: Mixed Footprint, coax & signal mix
HSV: Mixed Footprint, signal only
HP3V: Mixed Footprint, 20-40 Amp power only (2W2, 3W3, 5W5, 8W8)
HP2V: Mixed Footprint, 10-20 Amp power only (2W2, 3W3, 5W5, 8W8)
HCV: Mixed Footprint, coax only (2W2, 3W3, 5W5, 8W8)

Special Deviations

Consult Factory

Board Mounting Options:

For Straight

Blank: 3.05mm (.120") clear hole
RM53: M3 Threaded (panel side) standoff with boardlock
RM54: 4-40 Threaded (panel side) standoff with boardlock
RM83: Non-Removable M3 screwlock, with standoff and boardlock
RM84: Non-Removable 4-40 screwlock, with standoff and boardlock

For Right Angle

Blank: 3.05mm (.120") clear hole
RM6: Metal bracket with boardlock

Panel Mounting Options:

Blank: 3.05mm (.120") clear hole
3F: M3 Front screwlock
3R: M3 Rear threaded insert
4F: 4-40 Front screwlock
4R: 4-40 Threaded rear insert
FM: Float-mount system
A514: Blind mate guide pin

Example: L717 TW B9W4 S MP3V 4F RM6

* indicates polarized inserts

