

REVISIONS			
LTR	DESCRIPTION	DATE	APPROVED
A	Delete paragraph 1.1 and 1.2 in their entirety and substitute new paragraph 1.1 as printed on page 2. Renumber paragraph 1.3 to 1.2.	8 May 85	S. Searcy
B	Change vendor similar part numbers.	7 Mar 86	S. Searcy
C	Increase acceleration to 75 g's. Add new manufacturer eligibility requirements.	11 Sep 86	S. Searcy
D	Changes in accordance with NOR 5945-E088.	25 Jan 00	K. Cottongim
E	Validation and update.	17 Sep 03	K. Cottongim

CURRENT DESIGN ACTIVITY CAGE CODE 037Z3
 DEFENSE LOGISTICS AGENCY
 DEFENSE SUPPLY CENTER COLUMBUS
 COLUMBUS, OHIO 43216-5000

Prepared in accordance with ASME Y14.100

Selected item drawing

REV																				
PAGE																				
REV																				
PAGE																				
REV STATUS OF PAGES	REV	E	E	E	E	E	E	E	E	E										
	PAGES	1	2	3	4	5	6	7	8											

PMIC N/A	PREPARED BY Richard A. Yannitti	DESIGN ACTIVITY DEFENSE ELECTRONICS SUPPLY CENTER DAYTON, OH 45444-5000
Original date of drawing 3 April 1985	CHECKED BY Max E. Lewis	TITLE RELAYS, ELECTROMAGNETIC, HIGH VIBRATION, DPDT, LOW LEVEL TO 1.0 AMPERE WITH INTERNAL DIODE FOR COIL TRANSIENT SUPPRESSION (SIMILAR TO MIL-PRF-39016/15)
	APPROVED BY Steven B. Searcy	
	SIZE A	CODE IDENT. NO. 14933
	REV E	PAGE 1 OF 8

1. SCOPE

1.1 Scope. This drawing describes the requirements for hermetically sealed, electromagnetic relays. This drawing provides a level of reliability assurance for acquisition of relays in accordance with MIL-PRF-39016 except as specified herein (see 3.4.1, 3.4.2, and 3.4.3). The relays supplied to this drawing shall be subjected to all the tests as specified in the group A table of MIL-PRF-39016 for an M-level relay (see 4.2).

1.2 Part or Identifying Number (PIN). The complete PIN shall be as follows:

84173
|

Drawing
number

-001
|

Dash number
(see table I)

2. APPLICABLE DOCUMENTS

2.1 Government documents.

2.1.1 Specifications, standards, and handbooks. The following specifications, standards, and handbooks form a part of this document to the extent specified herein. Unless otherwise specified, the issues of these documents are those listed in the issue of the Department of Defense Index of Specifications and Standards (DoDISS) and supplement thereto, cited in the solicitation (see 6.3).

SPECIFICATIONS

FEDERAL

A-A-55485/5 - Mounting Pads, Electrical-Electronic Component, Lead Conversion, .200 or .230 Diameter Pin Center to a Grid Pattern.

DEPARTMENT OF DEFENSE

MIL-PRF-39016 - Relays, Electromagnetic, Established Reliability, General Specification For.
MIL-PRF-39016/15 - Relays, Electromagnetic, Established Reliability, DPDT, Low Level to 1.0 Ampere With Internal Diode for Coil Transient Suppression.

STANDARDS

DEPARTMENT OF DEFENSE

MIL-STD-1285 - Marking of Electrical and Electronic Parts.

(Unless otherwise indicated, copies of federal and military specifications, standards, and handbooks are available from the Document Automation and Production Service, Building 4D (DPM-DODSSP), 700 Robbins Avenue, Philadelphia, PA 19111-5094.)

2.2 Order of precedence. In the event of a conflict between the text of this document and the references cited herein, the text of this document takes precedence. Nothing in this document, however, supersedes applicable laws and regulations unless a specific exemption has been obtained.

DEFENSE ELECTRONICS SUPPLY CENTER DAYTON, OHIO	SIZE A	CODE IDENT NO. 14933	DWG NO. 84173
		REV E	PAGE 2

3. REQUIREMENTS

3.1 Item requirements. The individual item requirements shall be in accordance with MIL-PRF-39016, MIL-PRF-39016/15, and as specified herein.

3.2 Interface and physical dimensions. The interface and physical dimensions shall be as specified in MIL-PRF-39016, MIL-PRF-39016/15, and herein (see figures 1 and 2).

3.3 Coil data (see table I).

3.3.1 Operate time. Operate time shall be 6.0 milliseconds maximum with rated coil voltage.

3.3.2 Release time. Release time shall be 4.0 milliseconds maximum from rated coil voltage.

3.4 Environmental characteristics. Relays shall meet all environmental requirements as specified in MIL-PRF-39016, MIL-PRF-39016/15, and herein.

3.4.1 Vibration (sinusoidal). As specified in MIL-PRF-39016 and MIL-PRF-39016/15, except vibration level shall be 100 g's and frequency range shall be 140 to 2,000 Hz.

3.4.2 Shock (specified pulse). As specified in MIL-PRF-39016 and MIL-PRF-39016/15, except peak value shall be 150 g's for 11 milliseconds.

3.4.3 Acceleration. As specified in MIL-PRF-39016 and MIL-PRF-39016/15, except peak value shall be 75 g's.

3.5 Physical. Physical requirements of the relays shall be as specified in MIL-PRF-39016, MIL-PRF-39016/15, and herein (see table I and figures 1 and 2).

3.5.1 Marking. Relays shall be marked in accordance with minimum marking requirements of MIL-PRF-39016, except the part number shall be in accordance with 1.2 herein. The "M39016/15-XXXX" part number shall not be used.

3.6 Conformance requirements. Relays furnished under this drawing shall have been subjected to, and passed all the requirements, tests, and inspections as specified herein.

3.6.1 Conformance inspection. Conformance inspection shall be in accordance with MIL-PRF-39016 and 4.2 herein.

3.7 Certificate of compliance. A certificate of compliance shall be required from manufacturers requesting to be a suggested source of supply.

3.8 Recycled, recovered, or environmentally preferable materials. Recycled, recovered, or environmentally preferable materials should be used to the maximum extent possible provided that the material meets or exceeds the operational and maintenance requirements, and promotes economically advantageous life cycle costs.

3.9 Workmanship. The relay shall be uniform in quality and free from any defects that will affect life, serviceability, or appearance.

DEFENSE ELECTRONICS SUPPLY CENTER DAYTON, OHIO	SIZE A	CODE IDENT NO. 14933	DWG NO. 84173
		REV E	PAGE 3

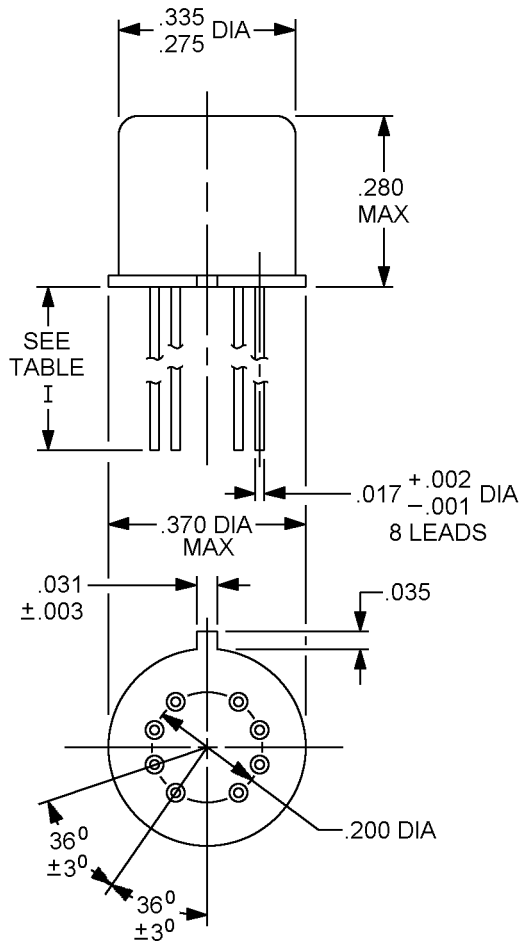

Inches	mm
.001	0.03
.002	0.05
.003	0.08
.017	0.43
.031	0.79
.035	0.89
.200	5.08
.275	6.99
.280	7.11
.335	8.51
.370	9.40

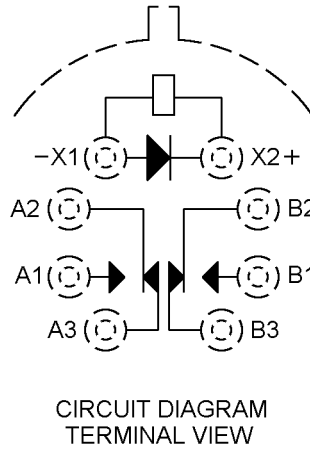

NOTES:

1. Dimensions are in inches.
2. Metric equivalents are given for general information only.
3. Unless otherwise specified, tolerance is $\pm .010$ (0.25 mm).
4. Terminal numbers shown above are for reference only. Numbers do not appear on relay.
5. Coil symbol optional in accordance with MIL-STD-1285.
6. Circuit diagram shown on part is the terminal view.
7. Relays shall have a (+) plus sign placed on the circuit diagram as shown.

FIGURE 1. Interface and physical dimensions.

DEFENSE ELECTRONICS SUPPLY CENTER DAYTON, OHIO	SIZE A	CODE IDENT NO. 14933	DWG NO. 84173
		REV E	PAGE 4

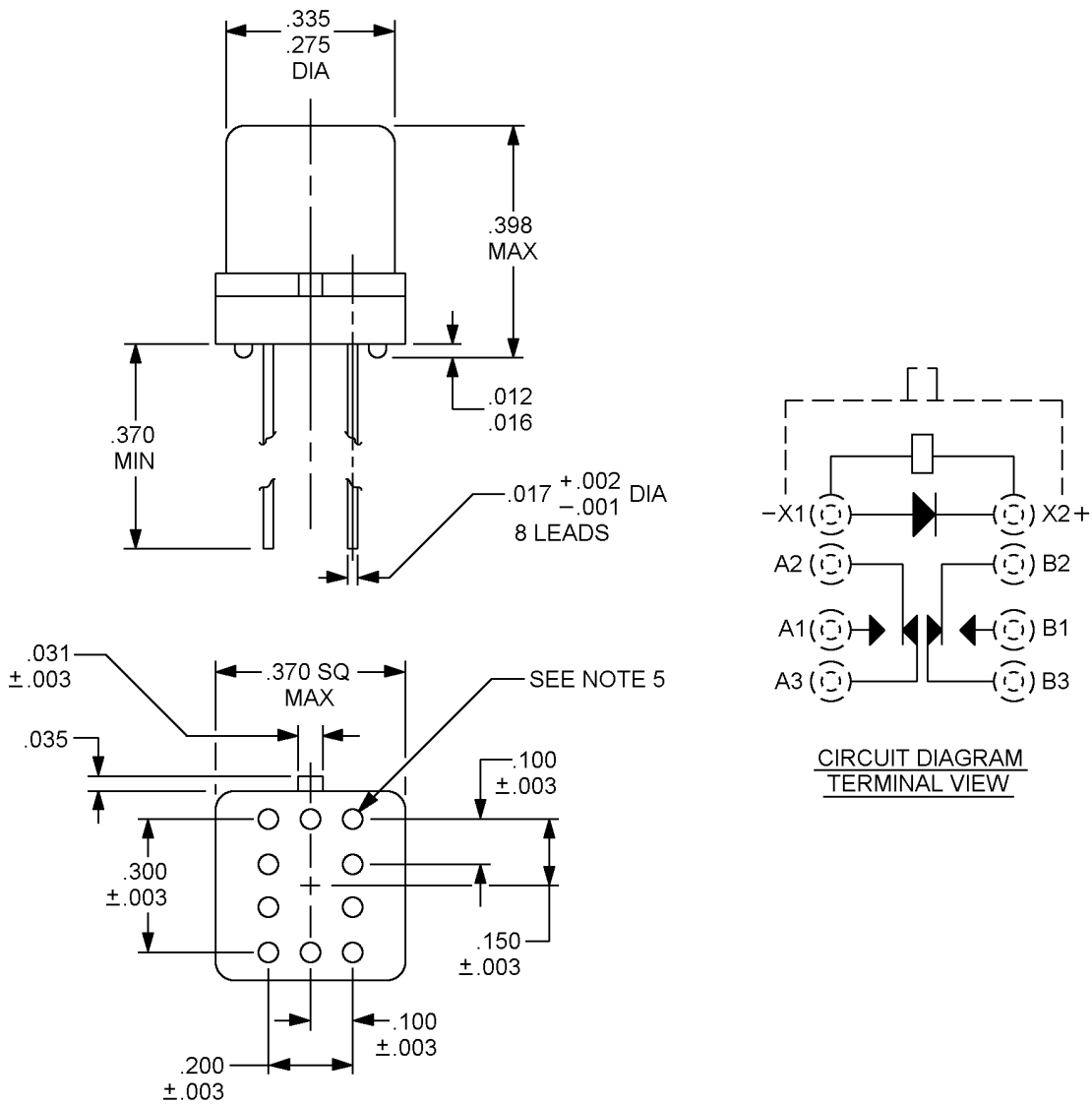

FIGURE 2. Interface and physical dimension relays supplied with spreader pad.

DEFENSE ELECTRONICS SUPPLY CENTER DAYTON, OHIO	SIZE A	CODE IDENT NO. 14933	DWG NO. 84173
		REV E	PAGE 5

Inches	mm
.001	0.03
.002	0.05
.003	0.08
.012	0.30
.016	0.41
.017	0.43
.031	0.79
.035	0.89
.100	2.54
.150	3.81
.200	5.08
.275	6.99
.300	7.52
.335	8.51
.370	9.40
.398	10.11

NOTES:

1. Dimensions are in inches.
2. Metric equivalents are given for general information only.
3. Unless otherwise specified, tolerance is $\pm .010$ (0.25 mm).
4. Spreader pads shall comply with the requirements of A-A-55485/5-003.
5. Dimensions and tolerances shown for the bottom view of the spreader pad are for the center to center locations of the holes in the spreader pad.
6. Shape optional within envelope dimension.
7. Coil symbol optional in accordance with MIL-STD-1285.
8. Terminal numbers shown above are for reference only. Numbers do not appear on relay.
9. Circuit diagram shown on part is the terminal view.
10. Relays shall have a (+) plus sign placed on the circuit diagram as shown.

FIGURE 2. Interface and physical dimension relays supplied with spreader pad - Continued.

DEFENSE ELECTRONICS SUPPLY CENTER DAYTON, OHIO	SIZE A	CODE IDENT NO. 14933	DWG NO. 84173
		REV E	PAGE 6

TABLE I. Dash numbers and characteristics. 1/

Dash numbers 84173-			Coil voltage (V dc) 2/		At +25°C				Over temperature range		
Lead length	Lead length	Spreader pads	Rated	Max	Coil resistance	Pickup voltage	Hold voltage	Drop-out voltage	Pickup voltage	Hold voltage	Drop-out voltage
.500 min	.187 +.040 -.010	(figure 2) 3/			ohms ±10%	(V dc) max	(V dc)	(V dc)	(V dc) max	(V dc)	(V dc)
001	007	013	5.0	5.8	50	3.5	1.4	0.22	4.6	2.5	0.14
002	008	014	6.0	8.0	70	4.2	2.0	0.27	5.5	3.2	0.18
003	009	015	9.0	12.0	155	6.2	3.0	0.54	8.2	4.9	0.35
004	010	016	12.0	16.0	235	8.3	4.0	0.63	11.0	6.5	0.41
005	011	017	18.0	24.0	610	12.5	6.0	0.77	16.5	10.0	0.59
006	012	018	26.5	32.0	1,130	18.0	8.0	1.23	22.0	13.0	0.89

1/ Each relay possesses high level and low level capabilities. However, relays previously tested or used above 10 mA resistive at 6 V dc maximum or peak ac open circuits are not recommended for subsequent use in low level applications.

2/ CAUTION: The use of any coil voltage less than the rated coil voltage will compromise the operation of the relay.

3/ Relays supplied with spreader pads (-013 through -018) shall have the pad rigidly attached.

4. VERIFICATION

4.1 Sampling and inspection. Unless otherwise specified, sampling and inspection procedures shall be performed in accordance with MIL-PRF-39106, except as modified herein.

4.2 Conformance inspection. Conformance inspection shall be in accordance with group A testing of MIL-PRF-39016. Group A testing shall be performed on each inspection lot and manufacturers shall keep lot records for 3 years (minimum), monitor for compliance to the prescribed procedures, and observe that satisfactory manufacturing conditions and records on lots are maintained for these relays.

4.2.1 Group A inspection. Group A inspection shall consist of all tests specified in MIL-PRF-39016, for failure rate level "M". For seal test, the radioisotope procedure or mass spectrometer method shall be performed.

5. PACKAGING

5.1 Packaging. For acquisition purposes, the packaging requirements shall be as specified in the contract or order (see 6.3). When actual packaging of materiel is to be performed by DoD personnel, these personnel need to contact the responsible packaging activity to ascertain requisite packaging requirements. Packaging requirements are maintained by the Inventory Control Point's packaging activity within the Military Department or Defense Agency, or within the Military Department's System Command. Packaging data retrieval is available from the managing Military Department's or Defense Agency's automated packaging files, CD-ROM products, or by contacting the responsible packaging activity.

DEFENSE ELECTRONICS SUPPLY CENTER DAYTON, OHIO	SIZE A	CODE IDENT NO. 14933	DWG NO. 84173
		REV E	PAGE 7

6. NOTES

(This section contains information of a general or explanatory nature which may be helpful, but is not mandatory.)

6.1 Notes. Only definitions of the notes specified in MIL-PRF-39016 will apply to this drawing.

6.2 Intended use. Relays conforming to this drawing are intended for use when military specifications do not exist and qualified military devices that will perform the required function are not available for OEM application. This drawing is intended exclusively to prevent the proliferation of unnecessary duplicate specifications, drawings, and stock catalog listings. When a military specification exists and the product covered by this drawing has been qualified for listing on QPL-39016, this drawing will be inactivated and will not be used for new design. The QPL-39016 product will be the preferred item for all applications.

6.3 Ordering data. The contract or purchase order should specify the following:

- a. Complete PIN (see 1.2).
- b. Requirements for delivery of one copy of the conformance inspection data or certificate of compliance that parts have passed conformance inspection with each shipment of parts by the manufacturer.
- c. Requirements for packaging and packing.

6.4 Users of record. Coordination of this document for future revisions are coordinated only with the suggested sources of supply and the users of record of this document. Requests to be added as a recorded user of this drawing should be in writing to: Defense Supply Center, Columbus, ATTN: DSCC/VAT, Post Office Box 3990, Columbus, OH 43216-5000 or by telephone (614) 692-0554 or DSN 850-0554.

6.5 Suggested sources of supply. Suggested sources of supply are listed herein. Additional sources will be added as they become available. For assistance in the use of this drawing, contact Defense Supply Center, Columbus, ATTN: DSCC-VAT, Post Office Box 3990, Columbus, OH 43216-5000 or by telephone (614) 692-0554 or DSN 850-0554.

DSCC drawing PIN 84173	Vendor similar designation or type number <u>1/</u>	Vendor CAGE	Vendor name and address
-001	MAVCD-5419-1	58614	Tyco Electronics-CII P. O. Box 520 1396 Charlotte Highway Fairview, NC 28730-0520 Phone: (828) 338-1087
-002	MAVCD-5419-2	"	
-003	MAVCD-5419-3	"	
-004	MAVCD-5419-4	"	
-005	MAVCD-5419-5	"	
-006	MAVCD-5419-6	"	
-007	MAVPD-5442-7	"	
-008	MAVPD-5442-8	"	
-009	MAVPD-5442-9	"	
-010	MAVPD-5442-10	"	
-011	MAVPD-5442-11	"	
-012	MAVPD-5442-12	"	
-013	MAVCD-5443-13S	"	
-014	MAVCD-5443-14S	"	
-015	MAVCD-5443-15S	"	
-016	MAVCD-5443-16S	"	
-017	MAVCD-5443-17S	"	
-018	MAVCD-5443-18S	"	

1/ Parts must be purchased to the DSCC PIN to assure that all performance requirements and tests are met.

DEFENSE ELECTRONICS SUPPLY CENTER DAYTON, OHIO	SIZE A	CODE IDENT NO. 14933	DWG NO. 84173
		REV E	PAGE 8