

and ordering information

For Datalites covered by MIL-L-3661B, see pages 18B-20B.

Note: Similar assemblies accommodating non-replaceable lamps - for mounting in 3/8" clearance holes - are described on pages 22B-24B.

MATERIALS AND FINISHES



Datalamp Holder

- **Mounting Bushing:** Aluminum, black anodize.
- **Collar and Flange Nut:** Aluminum. Standard finish - black anodize. Optional - clear anodize.
- **Mounting Nut:** Brass, white nickel finish.
- **Internal-tooth Lockwasher:** Phosphor bronze, white nickel finish.
- **Terminals:** Phosphor bronze, gold plated.

Data Cap

- **Lens:** High heat resisting plastic. Spring mounted, rotatable.
- **Lens Holder:** Aluminum. Standard finish - black anodize. Optional - clear anodize.

Legend Specifications: See page 25B.

 Amp "53" Taper Pin Receptacles	 Solder Blade Terminals	Dim. "A"	Data Cap Number*
250-9038-1431-504	250-7438-1431-504	29/32"	250-1431-500
250-9038-1471-504	250-7438-1471-504	29/32"	250-1471-500
250-9038-3331-504	250-7438-3331-504	29/32"	250-3331-500
250-9038-1531-504	250-7438-1531-504	29/32"	250-1531-500
250-9038-1631-504	250-7438-1631-504	29/32"	250-1631-500
_____	_____	1.428"	250-1471-500
_____	_____	1.428"	250-3331-500
_____	253-6939-1431-504	63/64"	253-1431-500
_____	253-6945-1431-504	1 1/16"	253-1431-500
250-9045-1431-504	250-7445-1431-504	63/64"	250-1431-500
250-9045-3331-504	250-7445-3331-504	63/64"	250-3331-500
250-9045-1531-504	250-7445-1531-504	63/64"	250-1531-500
250-9045-1631-504	250-7445-1631-504	63/64"	250-1631-500
250-9038-1431-504	250-7438-1431-504	29/32"	250-1431-500
250-9038-3331-504	250-7438-3331-504	29/32"	250-3331-500
250-9038-1531-504	250-7438-1531-504	29/32"	250-1531-500
250-9038-1631-504	250-7438-1631-504	29/32"	250-1631-500

*DATA CAP LENS COLORS

1 - Red	5 - White
+2 - Green	(translucent)
3 - Yellow (amber)	6 - Light Yellow
+4 - Blue	7 - Clear (colorless)

* The part numbers in the large chart above designate complete indicators with red data cap. To obtain other colors, change the last digit in code block three.

Example: 250-8738-1433-504 (Yellow Amber).

+ Blue and green are not recommended for use with neon.

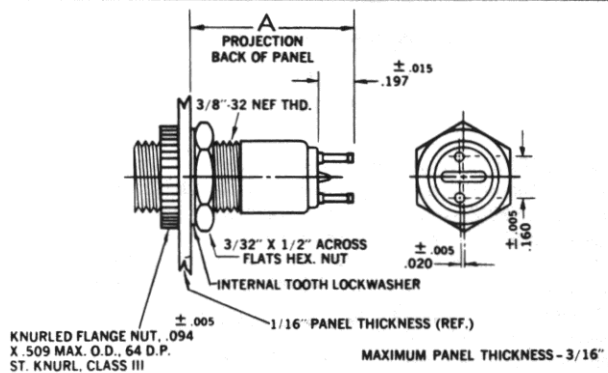

250-3331-500

250-1431-500

