

microLED® Optopipe®

Optical Light Pipe, Illuminated Corner

Dialight

515-1036

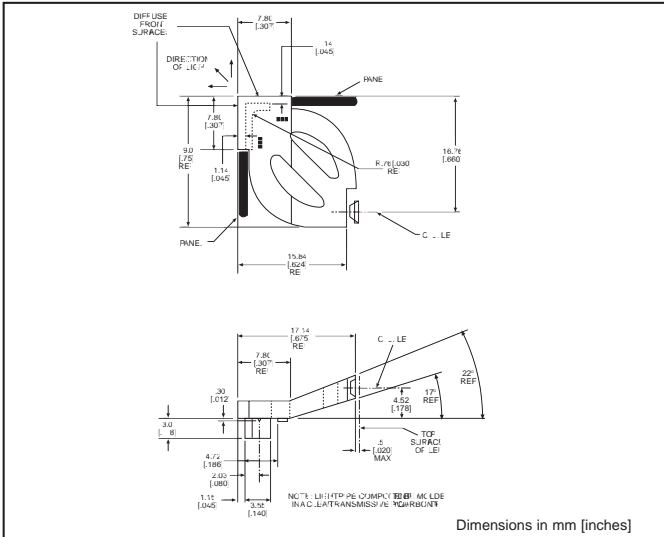

MicroLED SMT LEDs for use with 515-1036

PART NO. PAGE

Recommended

597-3xx1-2xx	1-21
597-77x1-2xx	1-23 & 1-24

Alternatives

597-3xxx-4xx	1-27 & 1-28
597-3xx1-4xx	1-28
597-3xx1-5xx	1-30
597-5004-4xx	1-26
597-5x11-4xx	1-27
597-5x12-4xx	1-26
597-5202-4xx	1-27
597-52x3-4xx	1-26
597-77x1-5xx	1-31

LED alternatives may not produce optimum light output

Features

- High transmissivity polycarbonate material
- UL94V-0 compliance
- ESD protection (circuit isolation from front panel)
- Even illumination of both panel faces
- Secures to panel by ultrasonic welding

LED Data

For absolute maximum ratings and other electrical and optical data on the recommended LEDs, refer to LED data sheets.

Operating/Storage Temperature

-30°C to +100°C

Dialight Optopipe® Light Pipe Description

This Optopipe® is ultrasonically welded inside the customer's plastic housing. The light pipe is welded to case at the L-shaped tab at the front of the part. The light pipe is not attached to the PCB at any point but floats above it. The squared-off end sticks through the plastic panel. The light pipe is textured to diffuse the light passing through it. The multi-guided design insures even illumination of the two indicating surfaces. The light pipe material is water clear transmissive polycarbonate rated UL94-V0, and has a 35% oxygen index.

Dialight can provide custom Optopipe® solutions for your applications.