

Straddle SMT type male connector for PCB  
 HDRA-E68FT2-( )+

For PCB

Straddle SMT

ANSI/SFF8441

RoHS

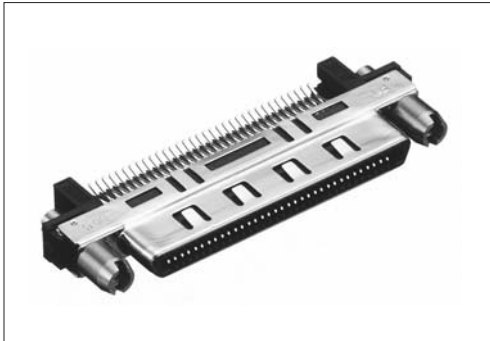

● Configuration of product Part No.

**HDRA- E 68 FT 2- ( )+**

- ① Series name
- ② No. of contacts: 68
- ③ Type of contact  
 FT: Straddle SMT type, female
- ④ PCB thickness: 0.5 mm
- ⑤ Lock screws  
 Blank: None  
 SL : provided

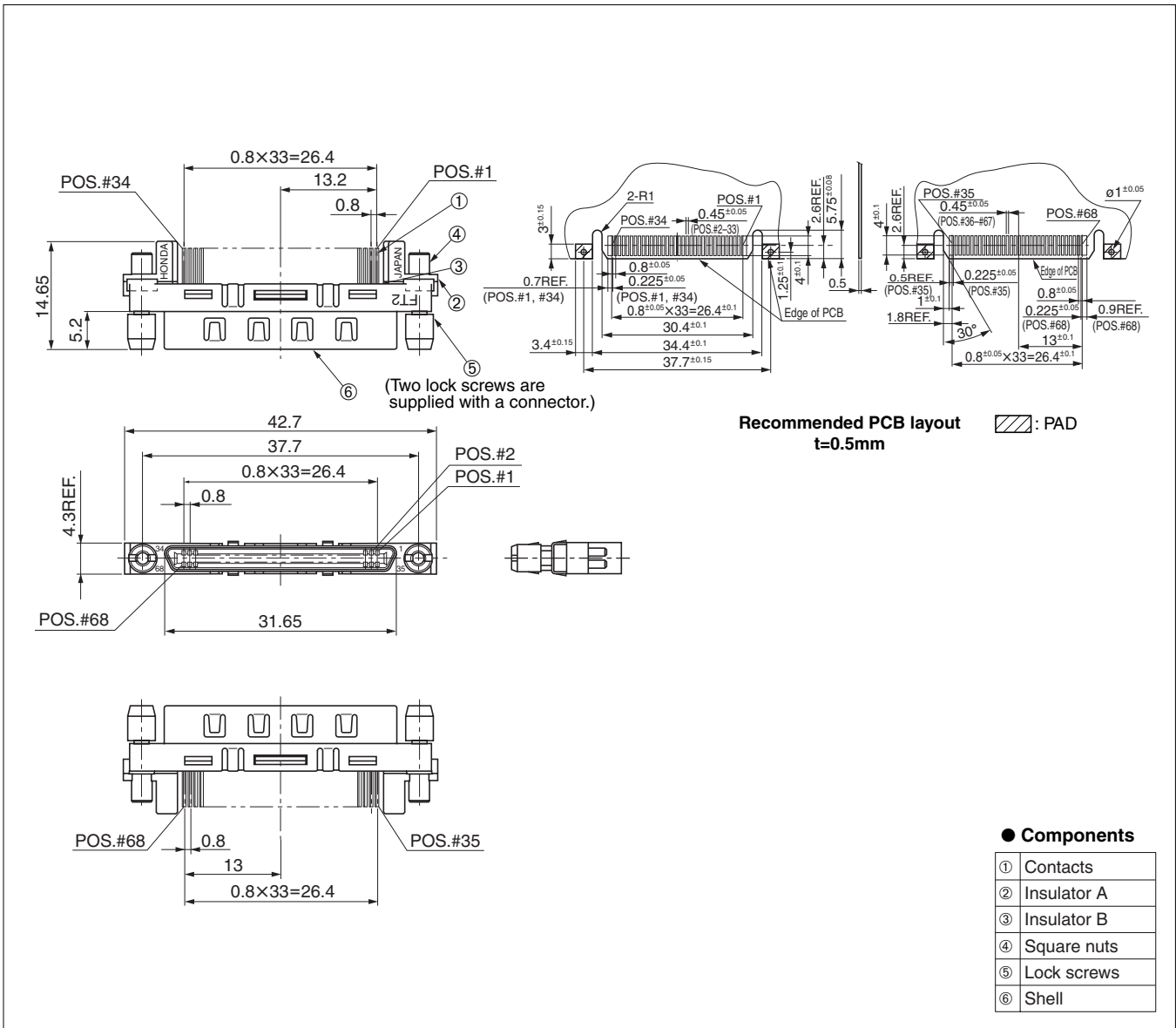

Mating connector: HDRA series IDC type male cable connector, or straddle SMT type male connector