

Screw lock
PCS-XE50SJ()U2

Accessories

Screw locks

SCSI-III

RoHS



● Configuration of product Part No.

PCS-XE 50 SJ() U2

① ② ③

- ① Series name
- ② Kinds of screw locks
 SJ1: The type not mounted on panel (Male screw size, #4-40UNC)
 SJ5: The type mounted on 1.6 mm panel (Male screw size, #4-40UNC)
 SJ6: The type mounted on 1.0 mm panel (Male screw size, #4-40UNC)
- ③ Female screw size
 U2: #2-56UNC

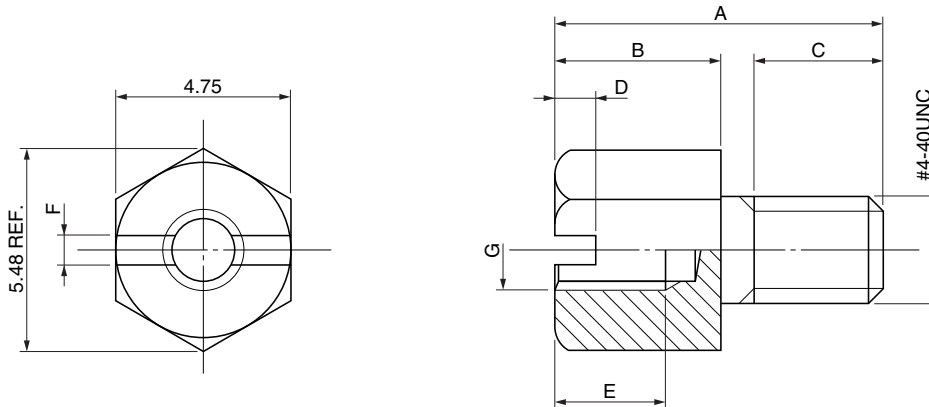

Note 1: SJ1 and SJ5 types are not slotted.

● Dimensions

Part No.	A	B	C	D	E	F	G
PCS-XE50SJ1U2	8.9	5.5	2.7	-	3	-	#2-56UNC
PCS-XE50SJ5U2		3.9	4.1		2.9		
PCS-XE50SJ6U2		4.5	3.5	1.1	3		

For use with backshell: PCS-E series Backshells with provision for preventing misinsertion