

Customer Information Sheet

DRAWING No.: R25-100XX02

SHEET 2 OF 2

IF IN DOUBT - ASK

©

NOT TO SCALE

THIRD ANGLE PROJECTION

ALL DIMENSIONS IN mm

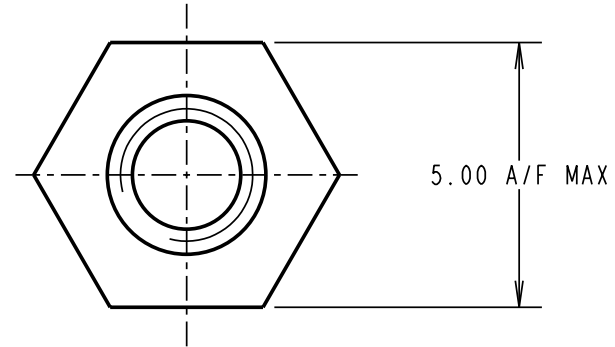
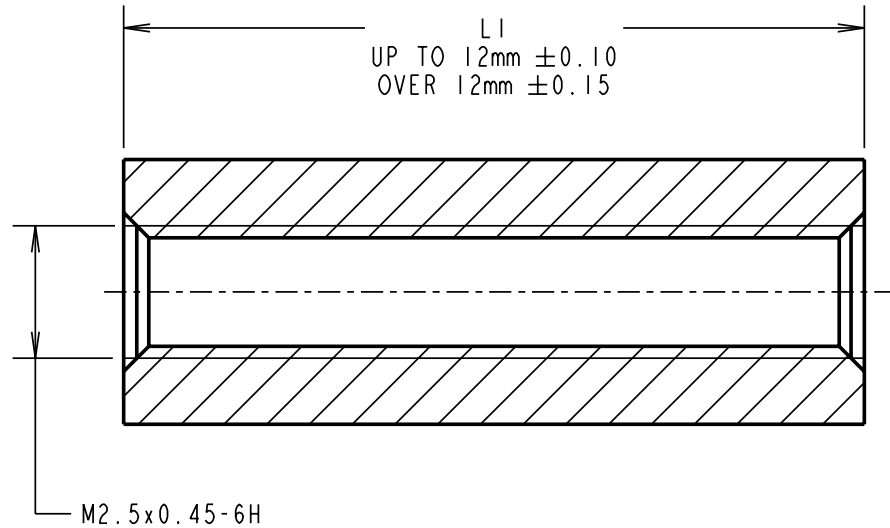

NOTES:

- R25-10025XX & R25-10033XX SPACERS MAY NOT HAVE A THRO TAPPED HOLE BUT WILL HAVE A MINIMUM THREAD LENGTH OF 10mm FROM BOTH ENDS.

PART No.	LI	PART No.	LI
R25-10004XX	4.00	R25-10013XX	13.00
R25-10005XX	5.00	R25-10014XX	14.00
R25-10006XX	6.00	R25-10015XX	15.00
R25-10007XX	7.00	R25-10016XX	16.00
R25-10008XX	8.00	R25-10017XX	17.00
R25-10009XX	9.00	R25-10018XX	18.00
R25-10010XX	10.00	R25-10020XX	20.00
R25-10011XX	11.00	R25-10025XX	25.00
R25-10012XX	12.00	R25-10033XX	33.00

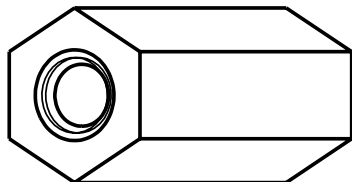

ORDER CODE:
R25-100XX02
 LENGTH LI IN mm _____

RA	4	10.09.08	10141
NAME	ISS.	DATE	C/NOTE
APPROVED:		R. ADDE	
CHECKED:		M.G. PLESTED	
DRAWN:		WJ BOURNE	
CUSTOMER REF.:			
ASSEMBLY DRG:			

HARWIN

HARWIN USA TEL: 603 893 5376 FAX: 603 893 5396 mis@harwin.com	HARWIN Europe (UK) TEL: 023 9231 4545 FAX: 023 9231 4590 mis@harwin.co.uk	HARWIN Asia TEL: +65 6 779 4909 FAX: +65 6 779 3868 mis@harwin.com.sg
--	--	--

THIS DRAWING AND ANY INFORMATION OR DESCRIPTIVE MATTER SET OUT HEREON ARE CONFIDENTIAL AND COPYRIGHT PROPERTY OF THE HARWIN GROUP AND MUST NOT BE DISCLOSED, LOANED, COPIED OR USED FOR MANUFACTURING, TENDERING OR FOR ANY OTHER PURPOSE WITHOUT THEIR WRITTEN PERMISSION.

TOLERANCES
 X. = ±1mm
 X.X = ±0.25mm
 X.XX = ±0.10mm
 X.XXX = ±0.01mm
 ANGLES = ±5°
 UNLESS STATED

MATERIAL:
 BRASS
 CW614N M TO BS EN 12164
 (CuZn39Pb3)
FINISH: NICKEL
S/AREA: mm²

TITLE:
 M2.5 HEXAGONAL
 FEMALE SPACER

DRAWING NUMBER:
R25-100XX02

SHT
 2 OF 2