

Overview

The KEMET ALP20 and ALT20/21 capacitors feature low ESR and high frequency impedance.

Applications

The ALP solder pin and ALT solder tag range details are incorporated herein, primarily, for maintenance and/or replacement purposes.

Benefits

- Solder tag (ALT) and DIN standard solder pin (ALP)
- Long life, up to 26,000 hours at +85°C (V_R, I_R applied)
- ALC snap-in should be considered for new designs



Part Number System

ALP	20A	682	AB	010	
Series	Version	Capacitance Code (μF)	Size Code	Rated Voltage (VDC)	
ALP = Solder pin ALT = Solder tag	20A = Standard 21A = Threaded Mounting Stud (ALT only)	First two digits represent significant figures. Third digit specifies number of zeros.	See Dimension Table	040 = 40 063 = 63 100 = 100 200 = 200	250 = 250 385 = 385 400 = 400 450 = 450

Performance Characteristics

Item	Performance Characteristics	
Capacitance Range	22 – 150,000 μ F	
Rated Voltage	40 – 450 VDC	
Operating Temperature	-40 to +85°C	
Storage Temperature Range	-55 to +85°C	
Capacitance Tolerance	-10/+30%, \pm 20% at 100 Hz/+20°C (only at 200 V)	
Operational Lifetime	D (mm)	Rated Voltage and Ripple Current at +85°C (hours)
	25	12,000
	30	15,000
	35	18,000
	40	26,000
End of Life Requirement	Δ C/C < \pm 10%	
Shelf Life	2,000 hours at +85°C or 30,000 hours at +40°C 0 VDC	
Leakage Current	I = 0.006 CV or 6,000 μ A (whichever is smaller)	
	C = rated capacitance (μ F), V = rated voltage (VDC). Voltage applied for 5 minutes at +20°C.	
Standards	IEC 60384-4	

Surge Voltage

Condition	Voltage (VDC)				
	40	63	100	200	385
\leq 30 second surge, 1,000 cycles at +85°C	46	72.5	115	230	423.5

Test Method & Performance

Endurance Life Test		
Conditions	Performance	
Temperature	+85°C	
Test Duration	5,000 hours	
Ripple Current	Available on request	
Voltage	The sum of DC voltage and the peak AC voltage must not exceed the rated voltage of the capacitor	
Performance	The following specifications will be satisfied when the capacitor is tested at +20°C:	
Capacitance Change	≤ 100 V	Within 15% of the initial value
	> 100 V	Within 10% of the initial value
Equivalent Series Resistance	Does not exceed 200% of the initial value	
Leakage Current	Does not exceed leakage current limit	

Dimensions – Millimeters (ALP)

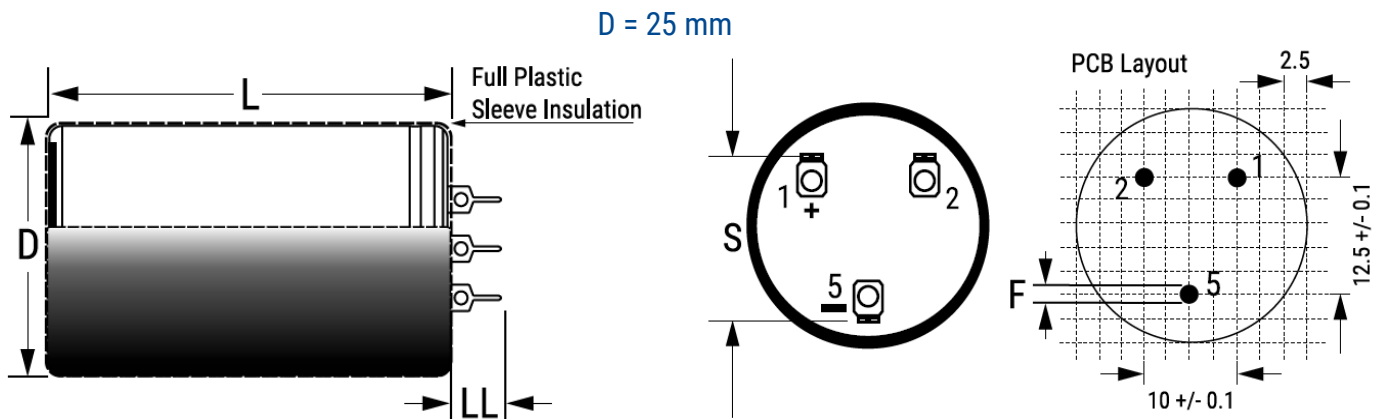

Connections: Hole 1 represents +ve. Hole 5 Represents -ve. Terminals 2,3, and 4 may be at negative terminal potential due to the presence of electrolyte. They are intended for mechanical connections only. It is recommended that they are soldered to the printed circuit board. Additional dummy pins are provided for stability. Note that the case and dummy pins may be at negative terminal potential

Size Code	Dimensions in mm			Approximate Weight Grams
	D	L	LL	
	±1	±2	±0.5	
AB	25	45	7.5	30
BB	30	45	7.5	50
CB	35	45	7.5	65
CD	35	55	7.5	75
DB	40	45	7.5	80
DD	40	55	7.5	95
DE	40	75	7.5	125
DF	40	105	7.5	170

Note: Dimensions include sleeving

Dimensions – Millimeters (ALP) cont.

D = 30/35 mm

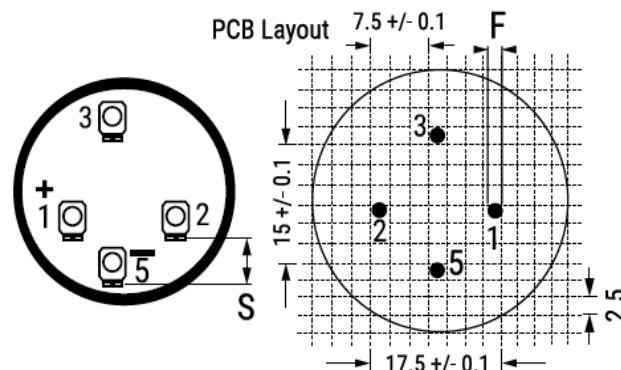
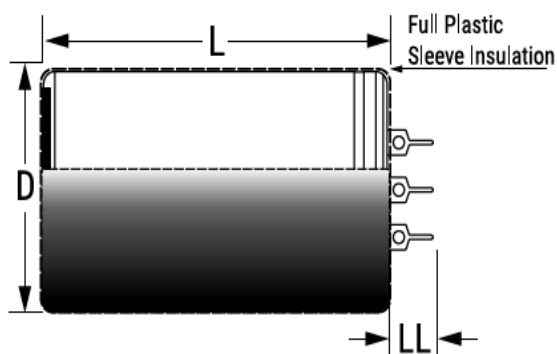

D = 40 mm

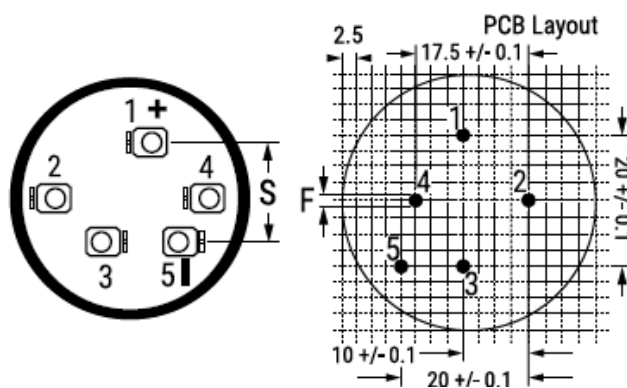
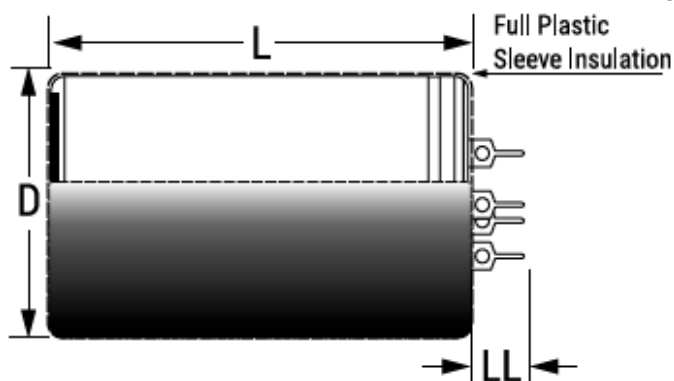

Connections: Hole 1 represents +ve. Hole 5 Represents -ve. Terminals 2,3, and 4 may be at negative terminal potential due to the presence of electrolyte. They are intended for mechanical connections only. It is recommended that they are soldered to the printed circuit board. Additional dummy pins are provided for stability. Note that the case and dummy pins may be at negative terminal potential

Size Code	Dimensions in mm			Approximate Weight Grams
	D	L	LL	
	±1	±2	±0.5	
AB	25	45	7.5	30
BB	30	45	7.5	50
CB	35	45	7.5	65
CD	35	55	7.5	75
DB	40	45	7.5	80
DD	40	55	7.5	95
DE	40	75	7.5	125
DF	40	105	7.5	170

Note: Dimensions include sleeving

Pin/Solder Tag – ALP20 and ALT20/21, +85°C

Dimensions – Millimeters (ALT)

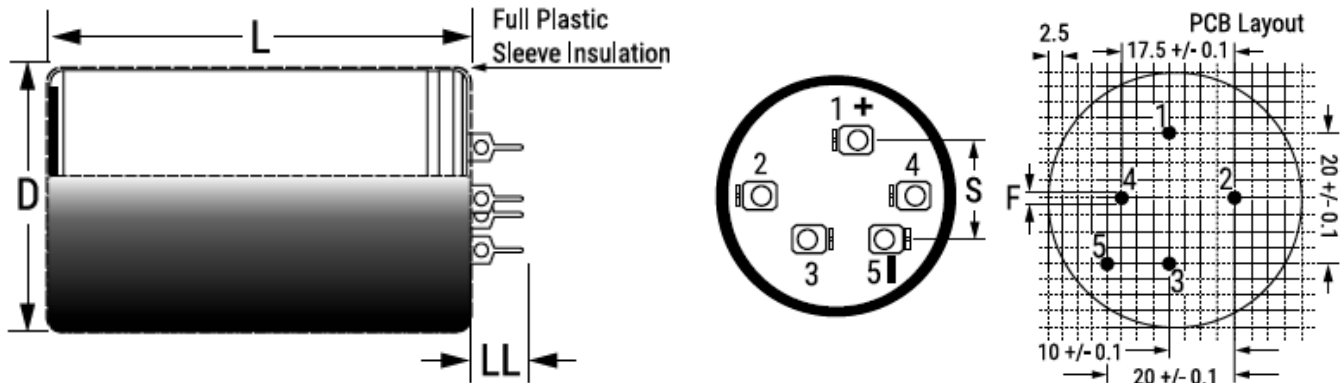

Size Code	Dimensions in mm				Mounting Stud (M x H)	Approximate Weight Grams	Mounting Clamp
	D	L	S	LL			
	±1	±2	±0.5	±1			
AA	25	35	10	10	M8 x 12	30	V2/H1
AB	25	45	10	10	M8 x 12	50	V2/H1
BB	30	45	10	10	M8 x 12	65	-
CB	35	45	10	10	M8 x 12	75	V3/H2/2736
CD	35	55	10	10	M8 x 12	80	V3/H2/2736
DB	40	45	10	10	M8 x 12	95	V9
DD	40	55	10	10	M8 x 12	125	V9
DE	40	75	10	10	M8 x 12	-	V9
DF	40	105	10	10	M8 x 12	170	V9

Note: Dimensions include sleeving

Shelf Life

The capacitance, ESR and impedance of a capacitor will not change significantly after extended storage periods, however the leakage current will very slowly increase. KEMET products are particularly stable and allow a shelf life in excess of three years at 40°C. See sectional specification under each product series for specific data.

Re-age (Reforming) Procedure

Apply the rated voltage to the capacitor at room temperature for a period of one hour, or until the leakage current has fallen to a steady value below the specified limit. During re-aging a maximum charging current of twice the specified leakage current or 5 mA (whichever is greater) is suggested.

Reliability

The reliability of a component can be defined as the probability that it will perform satisfactorily under a given set of conditions for a given length of time.

In practice, it is impossible to predict with absolute certainty how any individual component will perform; thus, we must utilize probability theory. It is also necessary to clearly define the level of stress involved (e.g. operating voltage, ripple current, temperature and time). Finally, the meaning of satisfactory performance must be defined by specifying a set of conditions which determine the end of life of the component.

Reliability as a function of time, $R(t)$, is normally expressed as: $R(t) = e^{-\lambda t}$

where $R(t)$ is the probability that the component will perform satisfactorily for time t , and λ is the failure rate.

Failure Rate

The failure rate is the number of components failing per unit time. The failure rate of most electronic components follows the characteristic pattern:

- Early failures are removed during the manufacturing process.
- The operational life is characterized by a constant failure rate.
- The wear out period is characterized by a rapidly increasing failure rate.

The failures in time (FIT) are given with a 60% confidence level for the various type codes. By convention, FIT is expressed as 1×10^{-9} failures per hour. Failure rate is also expressed as a percentage of failures per 1,000 hours.

e.g., 100 FIT = 1×10^{-7} failures per hour = 0.01%/1,000 hours

End of Life Definition

Catastrophic Failure: short circuit, open circuit or safety vent operation

Parametric Failure:

- Change in capacitance $> \pm 10\%$
- Leakage current $>$ specified limit
- ESR $> 2 \times$ initial ESR value

Failure Rate cont.

MTBF

The mean time between failures (MTBF) is simply the inverse of the failure rate.

$$\text{MTBF} = 1/\lambda$$

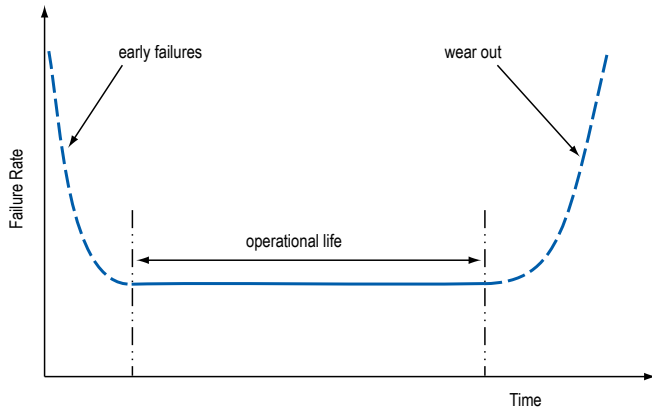

Environmental Compliance

As an environmentally conscious company, KEMET is working continuously with improvements concerning the environmental effects of both our capacitors and their production. In Europe (RoHS Directive) and in some other geographical areas like China, legislation has been put in place to prevent the use of some hazardous materials, such as lead (Pb), in electronic equipment. All products in this catalog are produced to help our customers' obligations to guarantee their products and fulfill these legislative requirements. The only material of concern in our products has been lead (Pb), which has been removed from all designs to fulfill the requirement of containing less than 0.1% of lead in any homogeneous material. KEMET will closely follow any changes in legislation world wide and makes any necessary changes in its products, whenever needed.

Some customer segments such as medical, military and automotive electronics may still require the use of lead in electrode coatings. To clarify the situation and distinguish products from each other, a special symbol is used on the packaging labels for RoHS compatible capacitors.

Because of customer requirements, there may appear additional markings such as LF = Lead Free or LFW = Lead Free Wires on the label.

Table 1A – Ratings & Part Number Reference (ALP)

VDC	Rated Capacitance (μF)	Capacitance Tolerance	Size Code	Case Size	Part Number
40	2200	-10/+30%	AB	25 x 45	ALP20A222AB040
40	4700	-10/+30%	CB	35 x 45	ALP20A472CB040
40	6800	-10/+30%	CD	35 x 55	ALP20A682CD040
40	10000	-10/+30%	DD	40 x 55	ALP20A103DD040
63	2200	-10/+30%	BB	30 x 45	ALP20A222BB063
63	3300	-10/+30%	CB	35 x 45	ALP20A332CB063
63	4700	-10/+30%	CD	35 x 55	ALP20A472CD063
63	6800	-10/+30%	DD	40 x 55	ALP20A682DD063
63	10000	-10/+30%	DE	40 x 75	ALP20A103DE063
63	15000	-10/+30%	DF	40 x 105	ALP20A153DF063
100	4700	-10/+30%	DE	40 x 75	ALP20A472DE100
250	1000	-10/+30%	DE	40 x 75	ALP20A102DE250
400	100	-10/+30%	BB	30 x 45	ALP20A101BB400
450	470	-10/+30%	DF	40 x 105	ALP20A471DF450
VDC	Rated Capacitance (μF)	Capacitance Tolerance	Size Code	Case Size	Part Number

Table 1B – Ratings & Part Number Reference (ALT)

VDC	Rated Capacitance (μF)	Capacitance Tolerance	Size Code	Case Size	Part Number
40	3300	-10/+30%	BB	30 x 45	ALT20A332BB040
40	4700	-10/+30%	CB	35 x 45	ALT20A472CB040
40	10000	-10/+30%	DD	40 x 55	ALT20A103DD040
63	1000	-10/+30%	AA	25 x 35	ALT20A102AA063
200	680	-10/+30%	CD	35 x 55	ALT20A681CD200
250	680	-10/+30%	DD	40 x 55	ALT20A681DD250
400	100	-10/+30%	BB	30 x 45	ALT20A101BB400
400	220	-10/+30%	CD	35 x 55	ALT20A221CD400
450	100	-10/+30%	BB	30 x 45	ALT20A101BB450
VDC	Rated Capacitance (μF)	Capacitance Tolerance	Size Code	Case Size	Part Number

Print Detail

- KEMET Logo
- Rated capacitance
- Capacitance tolerance
- Rated voltage
- Climatic Category
- Date of manufacture and Batch No.
- Article code

Construction Data

The manufacturing process begins with the anode foil being electrochemically etched to increase the surface area and then “formed” to produce the aluminum oxide layer. Both the anode and cathode foils are then interleaved with absorbent paper and wound into a cylinder. During the winding process, aluminum tabs are attached to each foil to provide the electrical contact.

The deck, complete with terminals, is attached to the tabs and then folded down to rest on top of the winding. The complete winding is impregnated with electrolyte before being housed in a suitable container, usually an aluminum can, and sealed. Throughout the process, all materials inside the housing must be maintained at the highest purity and be compatible with the electrolyte.

Each capacitor is aged and tested before being sleeved and packed. The purpose of aging is to repair any damage in the oxide layer and thus reduce the leakage current to a very low level. Aging is normally carried out at the rated temperature of the capacitor and is accomplished by applying voltage to the device while carefully controlling the supply current. The process may take several hours to complete.

Damage to the oxide layer can occur due to variety of reasons:

- Slitting of the anode foil after forming
- Attaching the tabs to the anode foil
- Minor mechanical damage caused during winding

A sample from each batch is taken by the quality department after completion of the production process. This sample size is controlled by the use of recognized sampling tables defined in BS 6001.

The following tests are applied and may be varied at the request of the customer. In this case the batch, or special procedure, will determine the course of action.

Electrical:

- Leakage current
- Capacitance
- ESR
- Impedance
- Tan Delta

Mechanical/Visual:

- Overall dimensions
- Torque test of mounting stud
- Print detail
- Box labels
- Packaging, including packed quantity

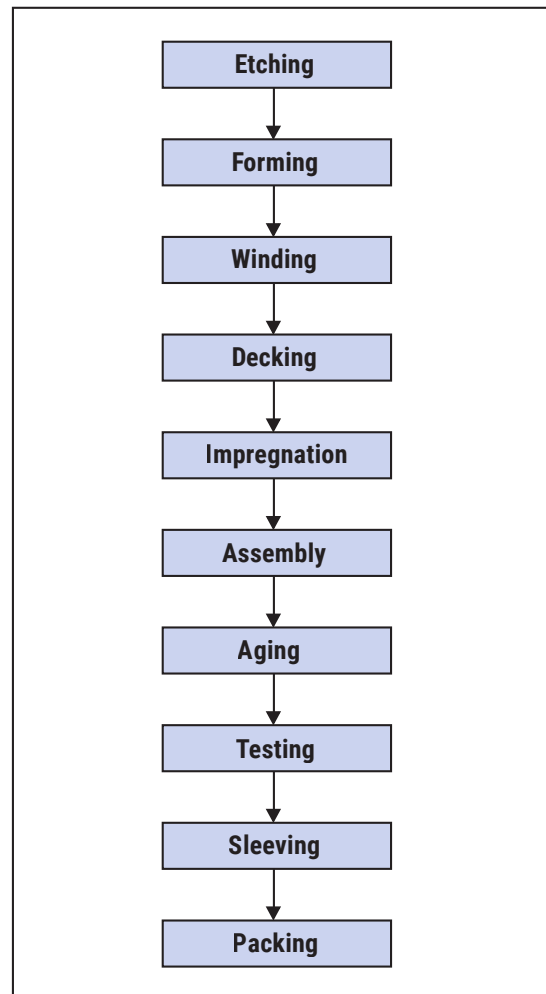
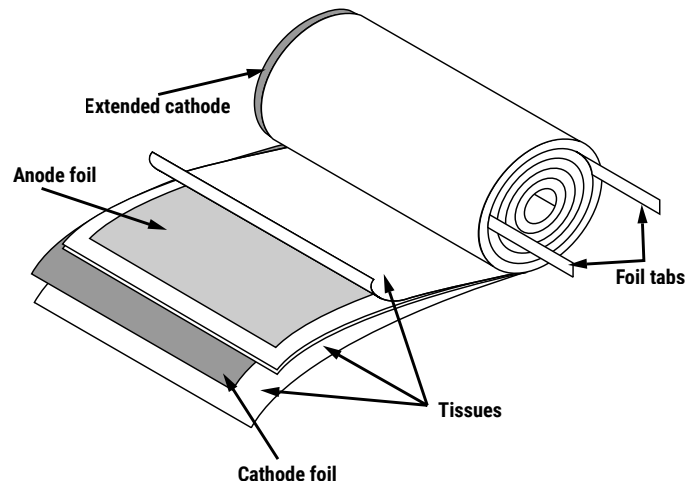

KEMET Electronics Corporation Sales Offices

For a complete list of our global sales offices, please visit www.kemet.com/sales.

Disclaimer

All product specifications, statements, information and data (collectively, the "Information") in this datasheet are subject to change. The customer is responsible for checking and verifying the extent to which the Information contained in this publication is applicable to an order at the time the order is placed. All Information given herein is believed to be accurate and reliable, but it is presented without guarantee, warranty, or responsibility of any kind, expressed or implied.

Statements of suitability for certain applications are based on KEMET Electronics Corporation's ("KEMET") knowledge of typical operating conditions for such applications, but are not intended to constitute – and KEMET specifically disclaims – any warranty concerning suitability for a specific customer application or use. The Information is intended for use only by customers who have the requisite experience and capability to determine the correct products for their application. Any technical advice inferred from this Information or otherwise provided by KEMET with reference to the use of KEMET's products is given gratis, and KEMET assumes no obligation or liability for the advice given or results obtained.

Although KEMET designs and manufactures its products to the most stringent quality and safety standards, given the current state of the art, isolated component failures may still occur. Accordingly, customer applications which require a high degree of reliability or safety should employ suitable designs or other safeguards (such as installation of protective circuitry or redundancies) in order to ensure that the failure of an electrical component does not result in a risk of personal injury or property damage.

Although all product-related warnings, cautions and notes must be observed, the customer should not assume that all safety measures are indicated or that other measures may not be required.