

REVISIONS	
ISSUE	CHANGES
2	CN 27545 C SD 8 NOV 85

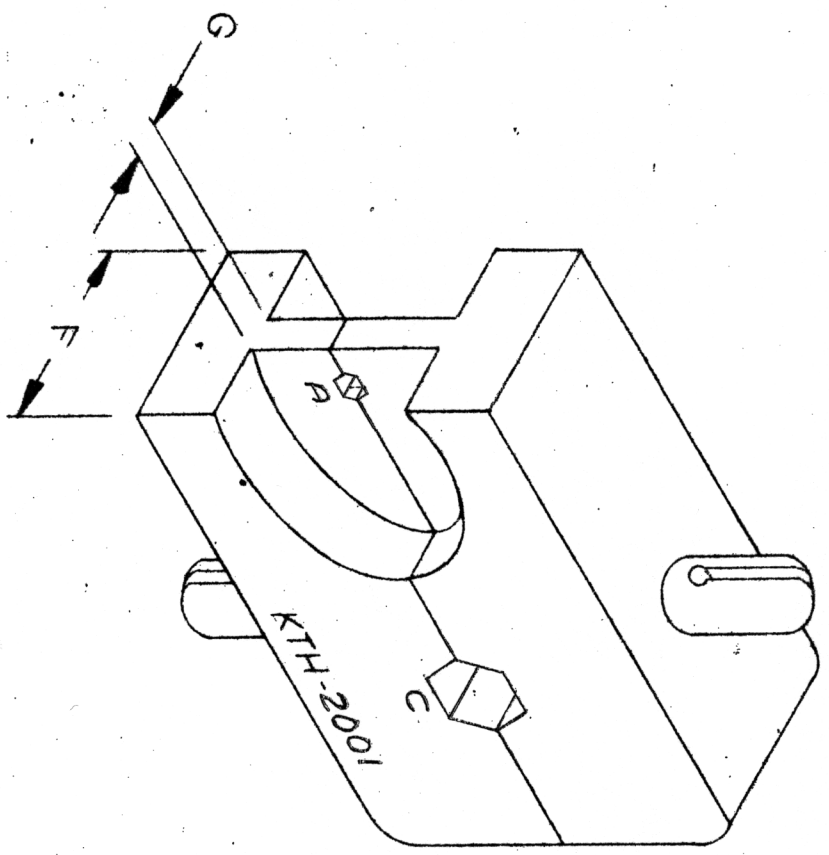

NOTES:
 1. FOR USE WITH RG-55, 58, 141, 142, 223 & 177
 BR/3077A CABLE GROUPS
 2. MATERIAL: ALLOY STEEL; FINISH: BLACK OXIDE

HEX SIZES (ACROSS FLATS)		DIE WIDTH	WEB WIDTH	HEX WIDTH		HEX WIDTH	
A	B	C	D	E	F	G	H
.069	—	.215	—	.400	.080	—	—

UNLESS OTHERWISE SPECIFIED:

1. TOLERANCES: FRACTIONS & 2 PLACE DECIMALS ± .010
2. REMOVE ALL BURRS, BREAK SHARP EDGES .005 MAX.
3. PLACE DECIMALS ± .004
3. NO FILLETS PERMITTED.
4. ANGLES ± 0° 30'
5. SURFACE ROUGHNESS 63 MICRONS RMS MAX.
1. 1 R. CONCENTRICITY OF ANY 2 DIAMETERS MAY NOT EXCEED HALF THE SUM OF THEIR TOLERANCES.
5. ALL DIMENSIONS PRIOR TO PLATING.

REF.	
FINISH	
SPEC	
MATL.	
SPEC	
CRIMP DIE	
DRAWN	DATE
JGL.	15 JUN 72
APPR.	DATE
KINGS ELECTRONICS	
40 MARBLEDALE ROAD	
TUCKAHOE, N. Y. 10707	
KTH-2001	