

THIS DRAWING IS UNPUBLISHED. RELEASED FOR PUBLICATION  
 © COPYRIGHT - By - ALL RIGHTS RESERVED.

| REVISIONS |     |                          |           |         |
|-----------|-----|--------------------------|-----------|---------|
| P         | LTR | DESCRIPTION              | DATE      | APVD    |
| B         |     | UPDATE PER ECO-16-002588 | 24 FEB 16 | CAS CAS |

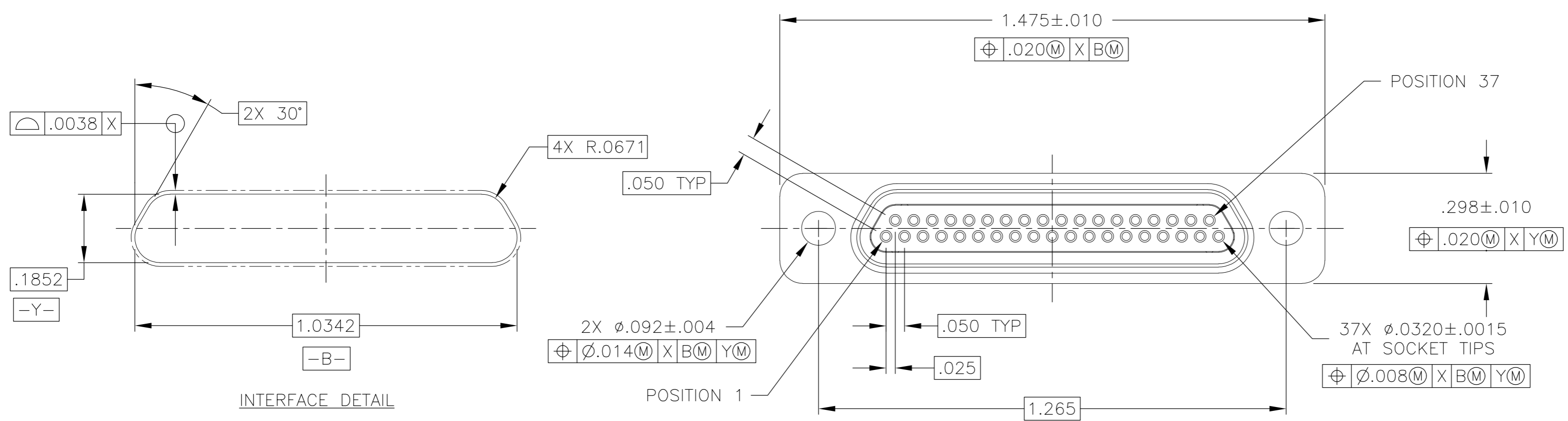

INTERFACE DETAIL

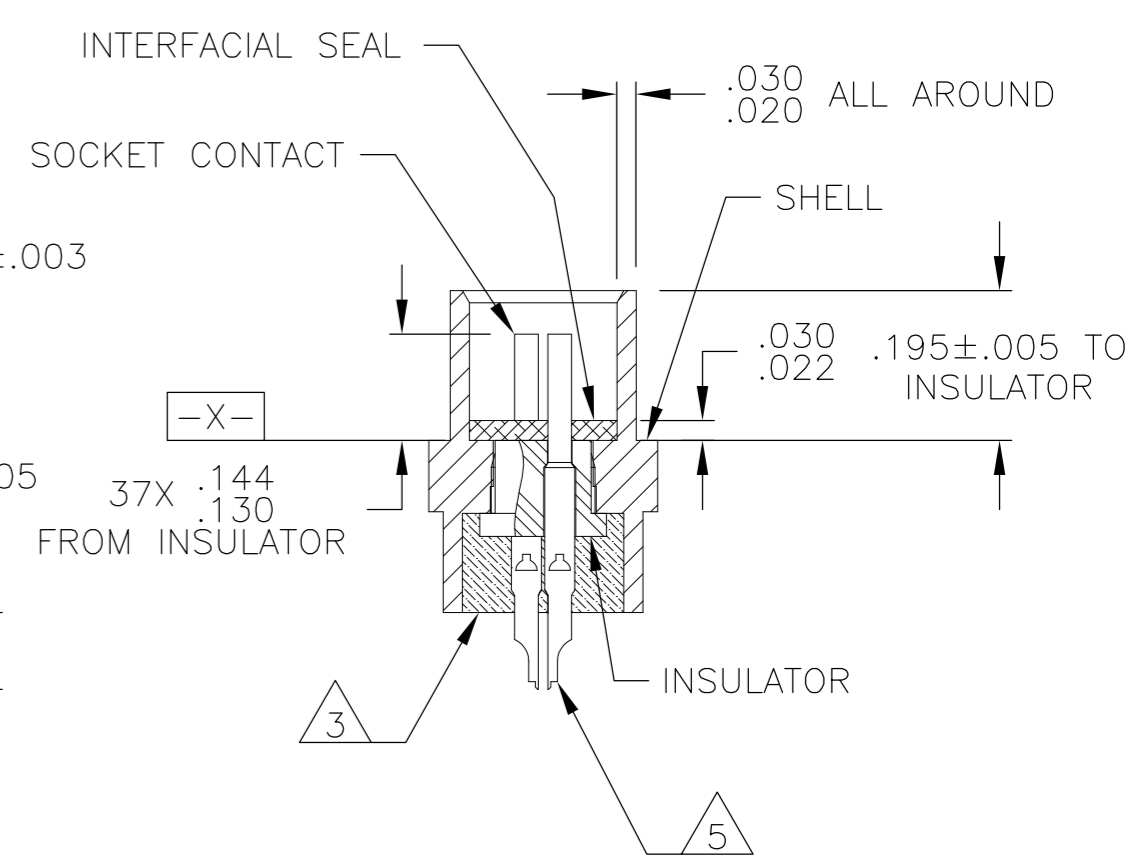
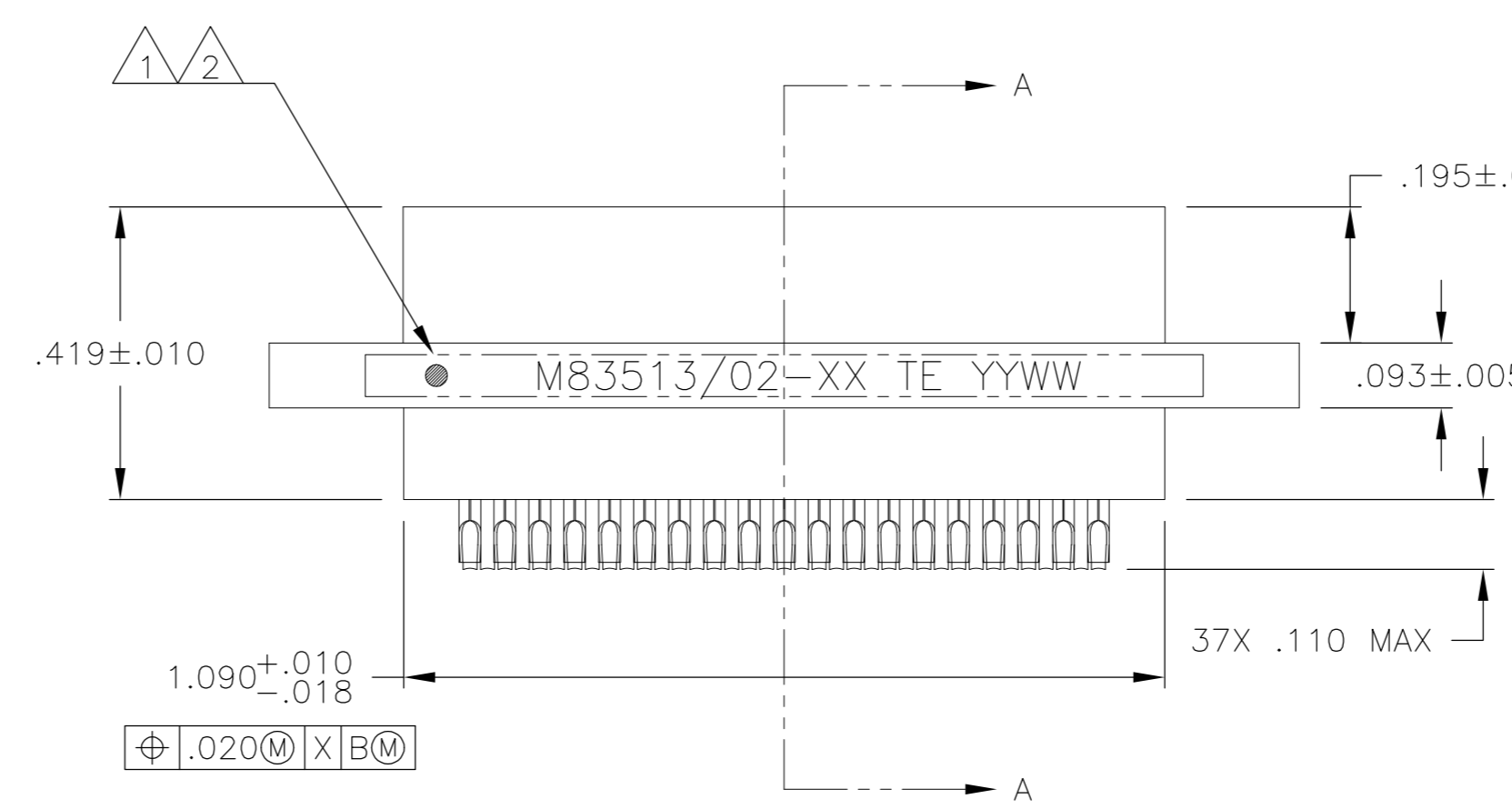

SECTION A-A

- 1 CONNECTOR SHALL BE MARKED IN ACCORDANCE WITH METHOD I OF MIL-STD-1285. MARKING SHALL CONTAIN THE MILITARY PIN, CAGE CODE (OR TE), AND DATE CODE. EXAMPLE: M83513/02-XX TE YYWW (WHERE XX IS PART OF THE PIN SHOWN IN THE "MIL-DTL-83513" COLUMN OF THE PART NUMBER TABLE, AND YYWW IS THE DATE CODE). TEXT HEIGHT SHALL BE .035 INCH MINIMUM.
- 2 POSITION 1 SHALL BE INDICATED BY AN IDENTIFIABLE MARK, LOCATED APPROXIMATELY AS SHOWN ON THE POSITION 1 SIDE OF THE CONNECTOR FLANGE. THIS MARK SHALL BE INCLUDED AS PART OF THE PART MARKING INFORMATION.
- 3 EPOXY ENCAPSULATION. EPOXY MAY WICK .050 INCH MAX FOR SOLDER CUPS.
- 4 ALL DIMENSIONS AND REQUIREMENTS ARE PER MIL-DTL-83513/2
- 5 CHAMFER ON SOLDER POTS ARE PARALLEL WITH THE SIDE OF CONNECTOR WITHIN 10°

|                                        |  |                                  |                                                                                   |           |
|----------------------------------------|--|----------------------------------|-----------------------------------------------------------------------------------|-----------|
| THIS DRAWING IS A CONTROLLED DOCUMENT. |  | DWN<br>B. ROMANCHUK<br>03 SEP 08 |                                                                                   |           |
| DIMENSIONS: INCHES                     |  | CHK<br>M. STORRY<br>03 SEP 08    |                                                                                   |           |
| TOLERANCES UNLESS OTHERWISE SPECIFIED: |  | APVD                             | NAME                                                                              |           |
| 0 PLC ± -                              |  | PRODUCT SPEC                     | RECEPTACLE ASSEMBLY,<br>MICRO-D PER MIL-DTL-83513/02,<br>MCKS SERIES, 37 POSITION |           |
| 1 PLC ± -                              |  | APPLICATION SPEC                 | SIZE                                                                              | CAGE CODE |
| 2 PLC ± .010                           |  | WEIGHT                           | A2                                                                                | 98278     |
| 3 PLC ± .005                           |  | CUSTOMER DRAWING                 | SCALE                                                                             | SHEET     |
| 4 PLC ± -                              |  |                                  | 4:1                                                                               | 1 of 2    |
| 5 ANGLES ± 1°                          |  |                                  |                                                                                   | REV B     |
| FINISH                                 |  |                                  |                                                                                   |           |
| MATERIAL SEE NOTES                     |  |                                  |                                                                                   |           |
|                                        |  |                                  |                                                                                   |           |

