

ANGLE 1

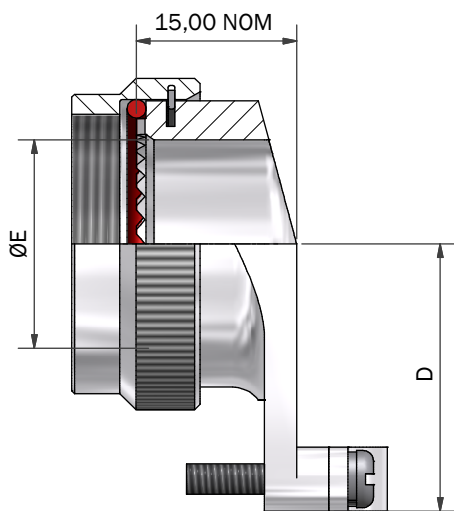

ANGLE 3

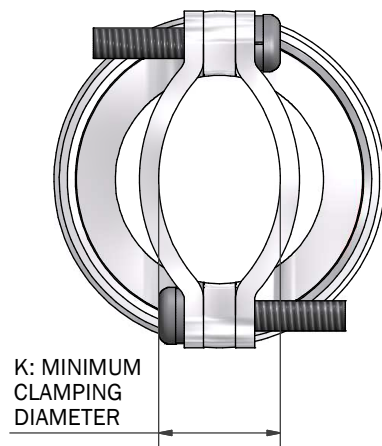
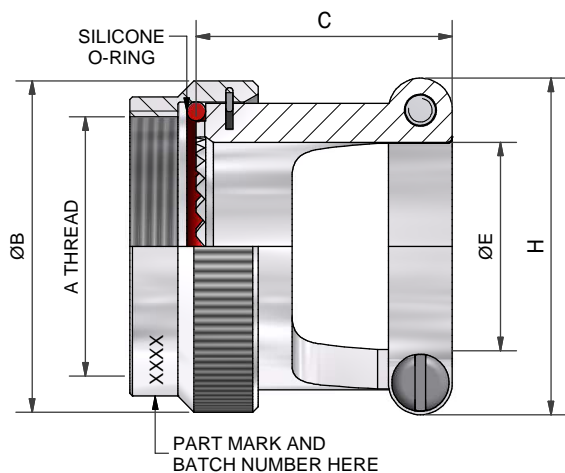
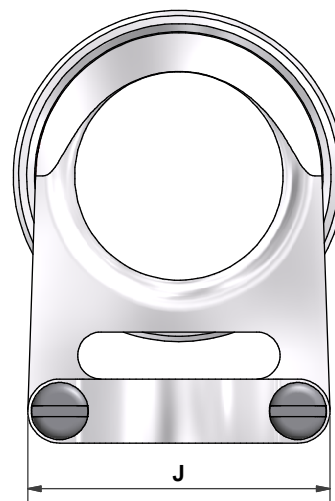

M: MINIMUM CLAMPING DIAMETER

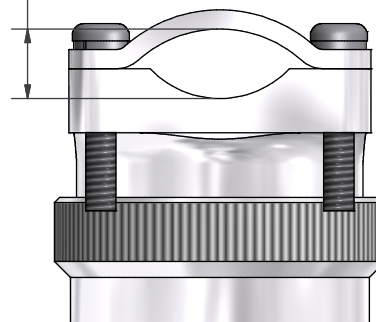

NOTE  
FASTENERS MATERIAL (STAINLESS STEEL)

DRAWN SALES APPR	J.CLARK	DATE 20/05/2009	3RD ANGLE PROJECTION NOT TO SCALE	 <b>POLAMCO</b> WESTON LOCK LOWER BRISTOL ROAD BATH BA2 1EP	PAGE 1 OF 2	UNLESS OTHERWISE SPECIFIED ALL DIMENSIONS IN MILLIMETRES
DESIGN APPR			THIS DRAWING IS COPYRIGHT AND THE PROPERTY OF POLAMCO LTD IT MUST NOT BE COPIED, USED FOR MANUFACTURE OR OTHERWISE DISCLOSED WITHOUT PRIOR WRITTEN CONSENT OF THE COMPANY.		ASSY USED ON: MIL-DTL-38999 SERIES III & IV	<b>MATERIAL</b> ALUMINIUM ALLOY 6262
QUAL APPR				<b>TITLE:</b>  STRAIN RELIEF ADAPTOR	NCAGE CODE U5792	
ISSUE 3		DCR 3969		<b>PART NUMBER:</b>  96H SERIES		DRAWING NO: P10756
WEIGHT	GENERAL TOL LINEAR +/-0.1MM ANGULAR +/- 1°					

TABLE 1

SHELL SIZE	A THREAD	ØB MAX	C MAX	D MAX	ØE MIN	H MAX	J MAX	K ±0,5 CLAMPING DIAMETER	M ±0,5 CLAMPING DIAMETER
09	M12 x 1.0	18,0	21,5	20,4	6,7	19,0	20,6	5,7	5,2
11	M15 x 1.0	21,0	21,5	21,4	10,1	22,2	22,2	6,9	5,2
13	M18 x 1.0	24,5	23,5	22,4	13,0	25,2	23,7	8,5	5,6
15	M22 x 1.0	27,5	23,5	23,4	16,1	28,5	26,9	10,4	6,4
17	M25 x 1.0	31,0	24,5	25,4	19,3	31,7	28,5	11,4	6,5
19	M28 x 1.0	34,0	27,5	27,9	21,8	34,9	31,7	14,9	7,0
21	M31 x 1.0	37,0	34,5	31,9	25,2	38,0	34,9	16,8	8,5
23	M34 x 1.0	40,0	37,5	35,4	28,1	42,8	38,0	23,9	9,4
25	M37 x 1.0	43,5	37,5	36,4	31,3	46,0	38,0	22,8	9,4

TABLE 2

CODE	FINISH
C	ELECTROLESS NICKEL
B	CADMIUM OLIVE DRAB OVER ELECTROLESS NICKEL
ZB	ZINC COBALT OLIVE DRAB OVER ELECTROLESS NICKEL
ZN	ZINC NICKEL BLACK PASSIVATE OVER ELECTROLESS NICKEL
G	BLACK ANODISE, SULPHURIC

LIST NOT EXHAUSTIVE, SEE PLATING TABLE FOR OTHER OPTIONS

**96H1-17-1-C**

SERIES \_\_\_\_\_

CONNECTOR INTERFACE \_\_\_\_\_



ANGLE \_\_\_\_\_

SHELL SIZE (TABLE 1) \_\_\_\_\_

MATERIAL \_\_\_\_\_

ALUMINIUM ALLOY

FINISH (TABLE 2) \_\_\_\_\_

<b>DRAWN</b>	J.CLARK	DATE 20/05/2009	 3RD ANGLE PROJECTION NOT TO SCALE	 <b>POLAMCO</b> WESTON LOCK LOWER BRISTOL ROAD BATH BA2 1EP	<b>PAGE 2</b> OF 2	UNLESS OTHERWISE SPECIFIED ALL DIMENSIONS IN MILLIMETRES
<b>SALES APPR</b>			THIS DRAWING IS COPYRIGHT AND THE PROPERTY OF POLAMCO LTD IT MUST NOT BE COPIED, USED FOR MANUFACTURE OR OTHERWISE DISCLOSED WITHOUT PRIOR WRITTEN CONSENT OF THE COMPANY.	<b>ASSY USED ON: MIL-DTL-38999 SERIES III &amp; IV</b>		<b>MATERIAL</b> ALUMINIUM ALLOY 6262
<b>DESIGN APPR</b>				<b>TITLE:</b>  <b>STRAIN RELIEF ADAPTOR</b>		
<b>QUAL APPR</b>				<b>PART NUMBER:</b>  <b>96H SERIES</b>		<b>NCAGE CODE U5792</b>
<b>ISSUE 3</b>	<b>DCR 3969</b>			<b>WEIGHT</b>	GENERAL TOL LINEAR +/-0.1MM ANGULAR +/- 1°	<b>DRAWING NO:</b> P10756