

SGGP.18A

Specification

PATENT PENDING

Part No.	SGGP.18A
Product Name	GPS/GLONASS SMT Patch Antenna
Features	18mm*18mm*4mm Single Feed SMT GPS: 1575MHz GLONASS: 1602MHz Patent pending RoHS Compliant

1. Introduction

This ceramic 18mm GPS/GLONASS patch antenna is mounted via SMT process and has been pre-tuned for a 50*50mm ground plane. Custom part no's tuned for different ground-plane or layout positions and taking into account the specific conditions in your device can be created and supplied by Taoglas.

2. Specification

Original Patch Specification tested on 50*50mm ground plane

NO.:	PARAMETER	SPECIFICATION	NOTES
1	Range of Receiving Frequency	GPS:1575.42 MHz ± 1.023 MHz GLONASS: 1602± 5 MHz	
2	Center Frequency	1592± 3MHz	With 50*50mm ground plane
3	Bandwidth	8MHz min	Return Loss <-10 dB
4	VSWR	2.0 max	Center Frequency
5	Gain at Zenith	GPS: 0.26dBic typ. GLONASS: 1.25dBic typ.	
8	Impedance	50 Ohms	
9	Frequency Temperature Coefficient (τf)	0 ± 20ppm / oC	-40°C to +85°C
10	Operating Temperature	-40°C to +85°C	

**Changes in user groundplane and environment will offset centre frequency

3. Electrical Specifications

3.1. Return Loss, SWR, Impedance, measured on the test fixture

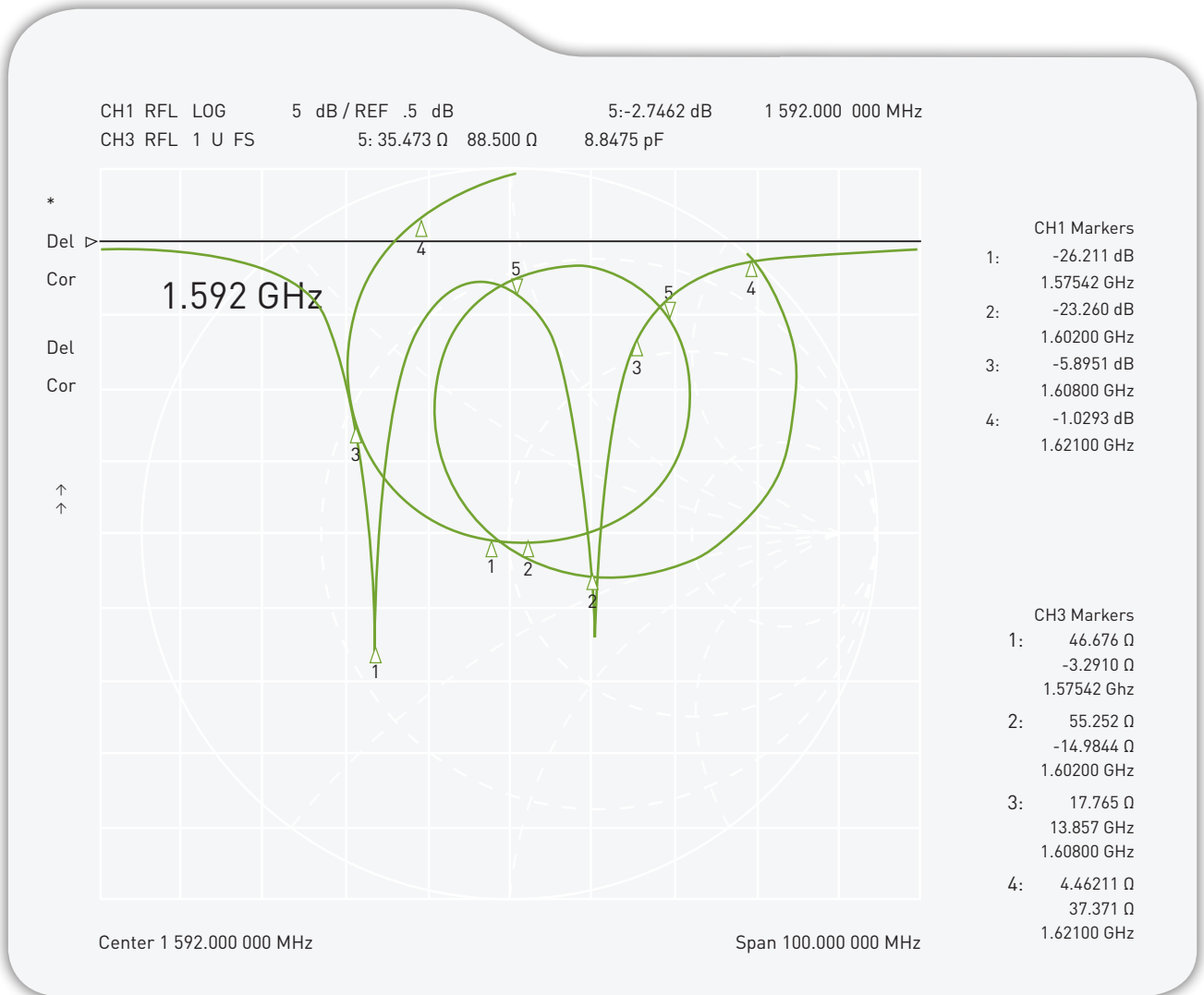

4. Radiation Patterns

4.1 1575MHz - XZ and YZ Plane

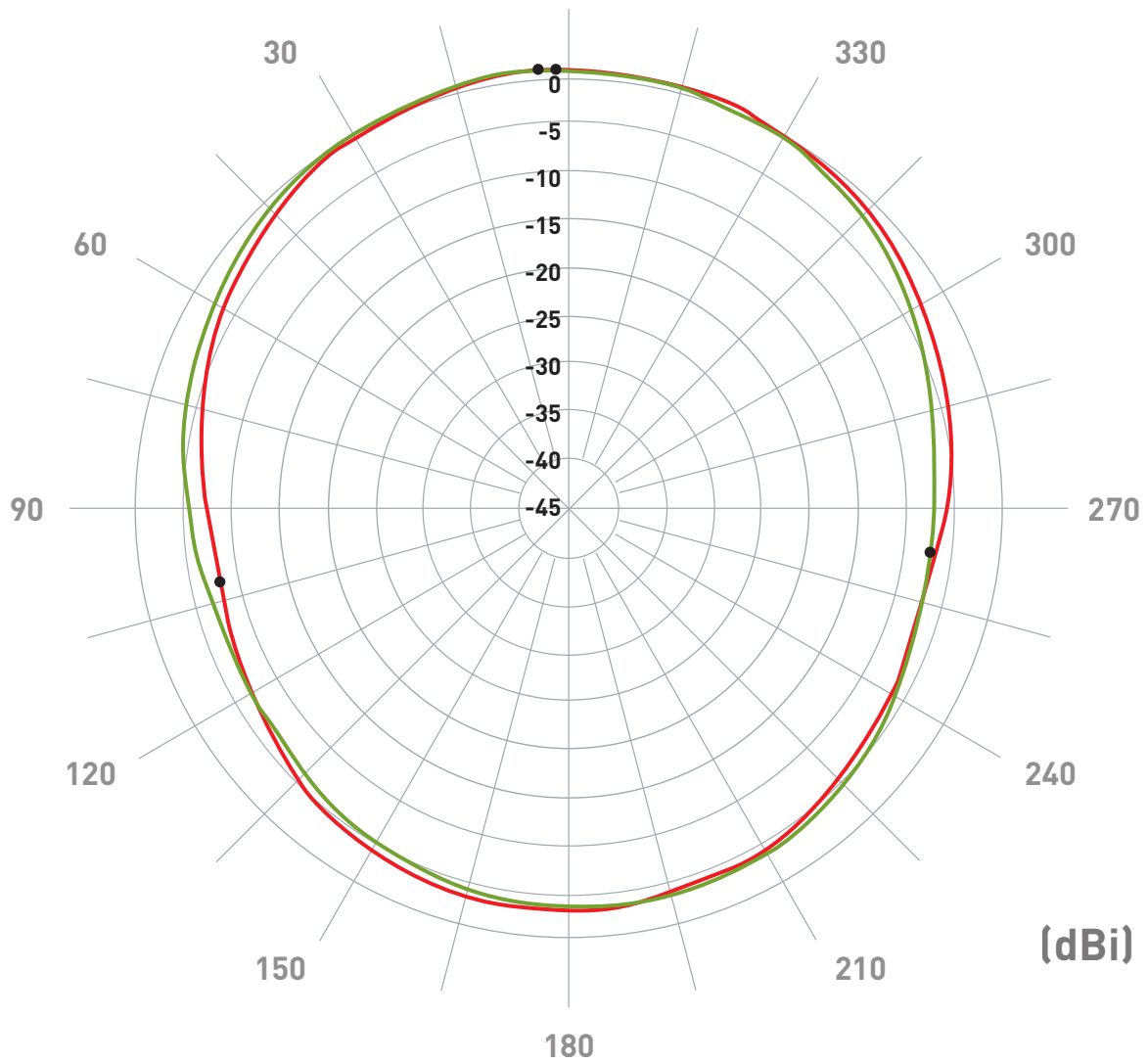

Pattern	Model No.	Test Mode	Freq (Mhz)	Max Gain (dBi)	Min Gain (dBi)	Avg. Gain (dBi)	Source Polar	Date
1	SGGP.18A	XZ	1575.42	0.72 / 2.00	-7.68 / 102.00	-2.81	V+H	2012/6/8
2	SGGP.18A	YZ	1575.42	0.82 / 4.00	-7.33 / 263.00	-2.79	V+H	2012/6/8

4.2 1602MHz - XZ and YZ Plane

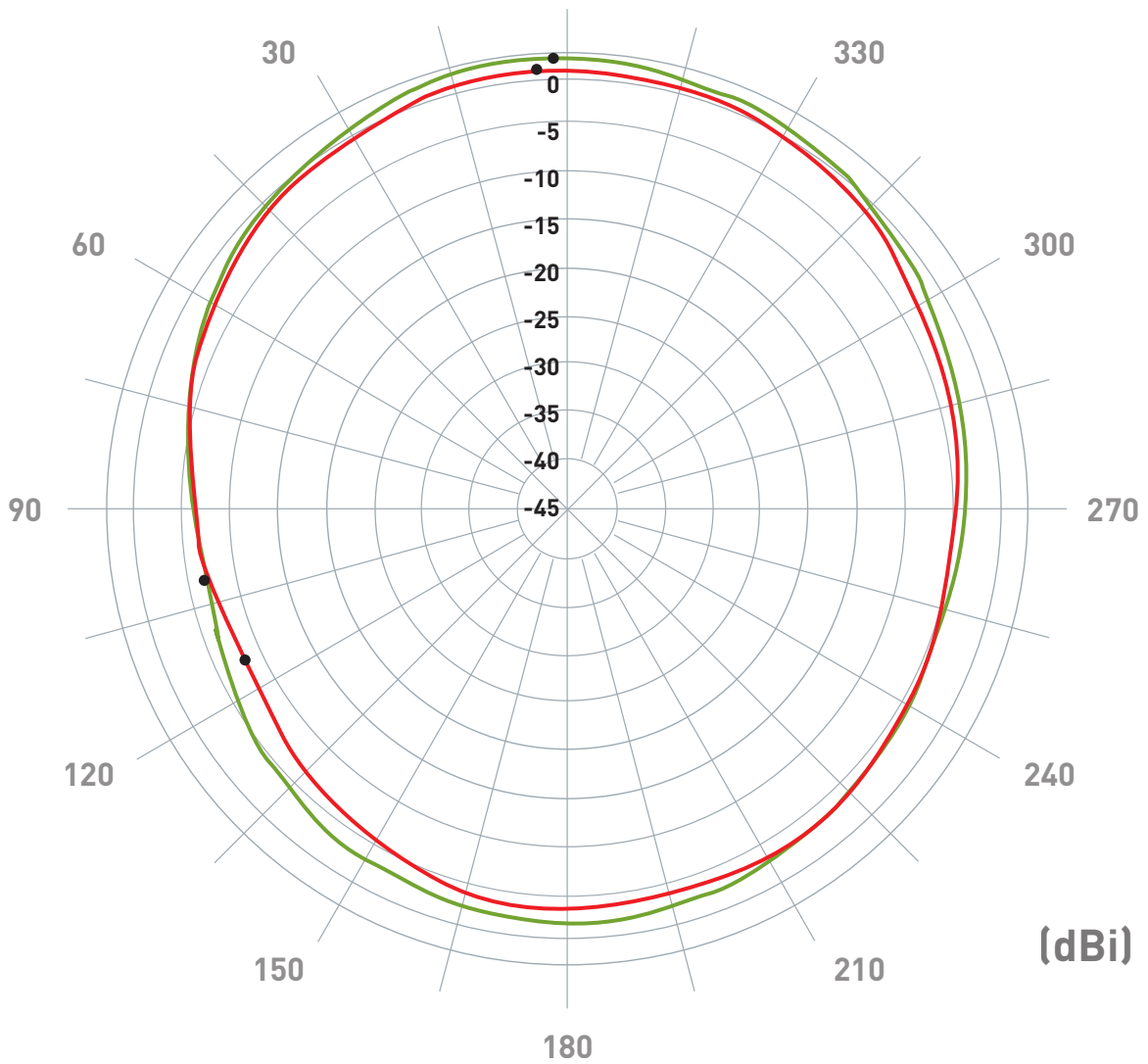

Pattern	Model No.	Test Mode	Freq (Mhz)	Max Gain (dBi)	Min Gain (dBi)	Avg. Gain (dBi)	Source Polar	Date
1	SGGP.18A	XZ	1602.00	1.25 / 4.00	-7.62 / 115.00	-2.19	V+H	2012/6/8
2	SGGP.18A	YZ	1602.00	2.27 / 2.00	-6.30 / 101.00	-1.28	V+H	2012/6/8

5. Mechanical Specifications

5.1 Antenna Dimensions and Drawing

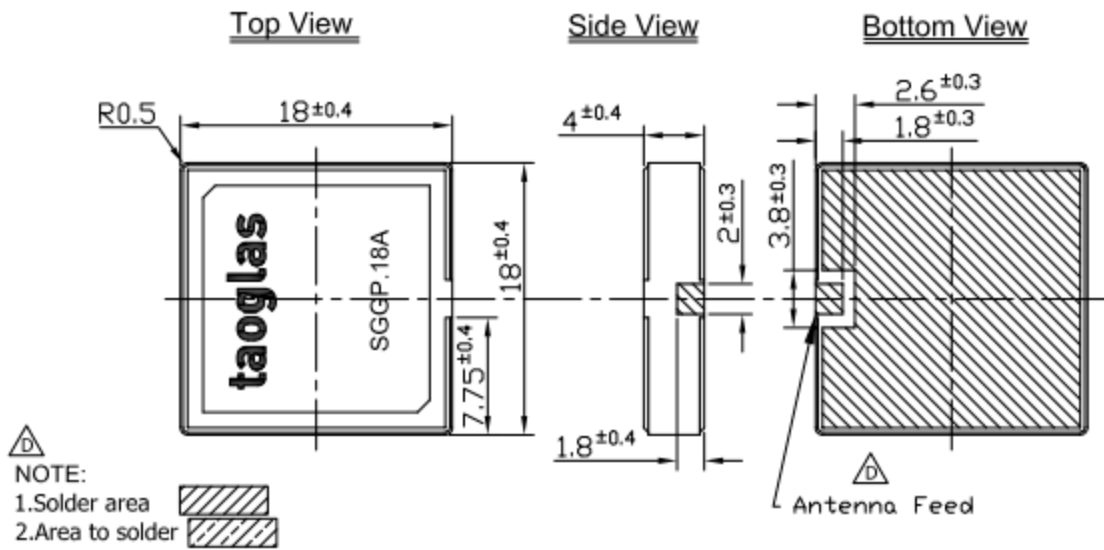

5.1.1 Footprint Copper Keepout Area

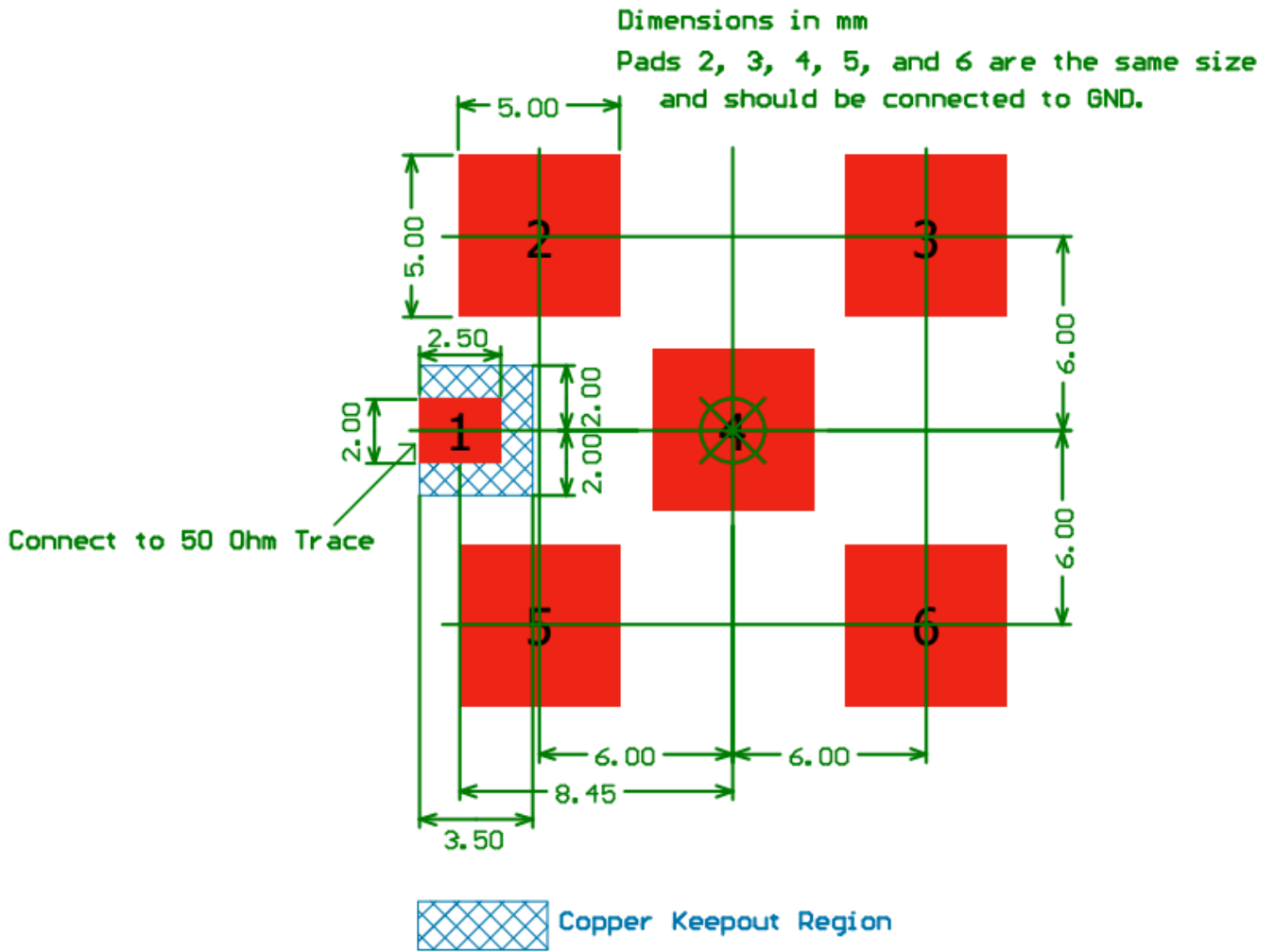

5.1.2 Paste Area

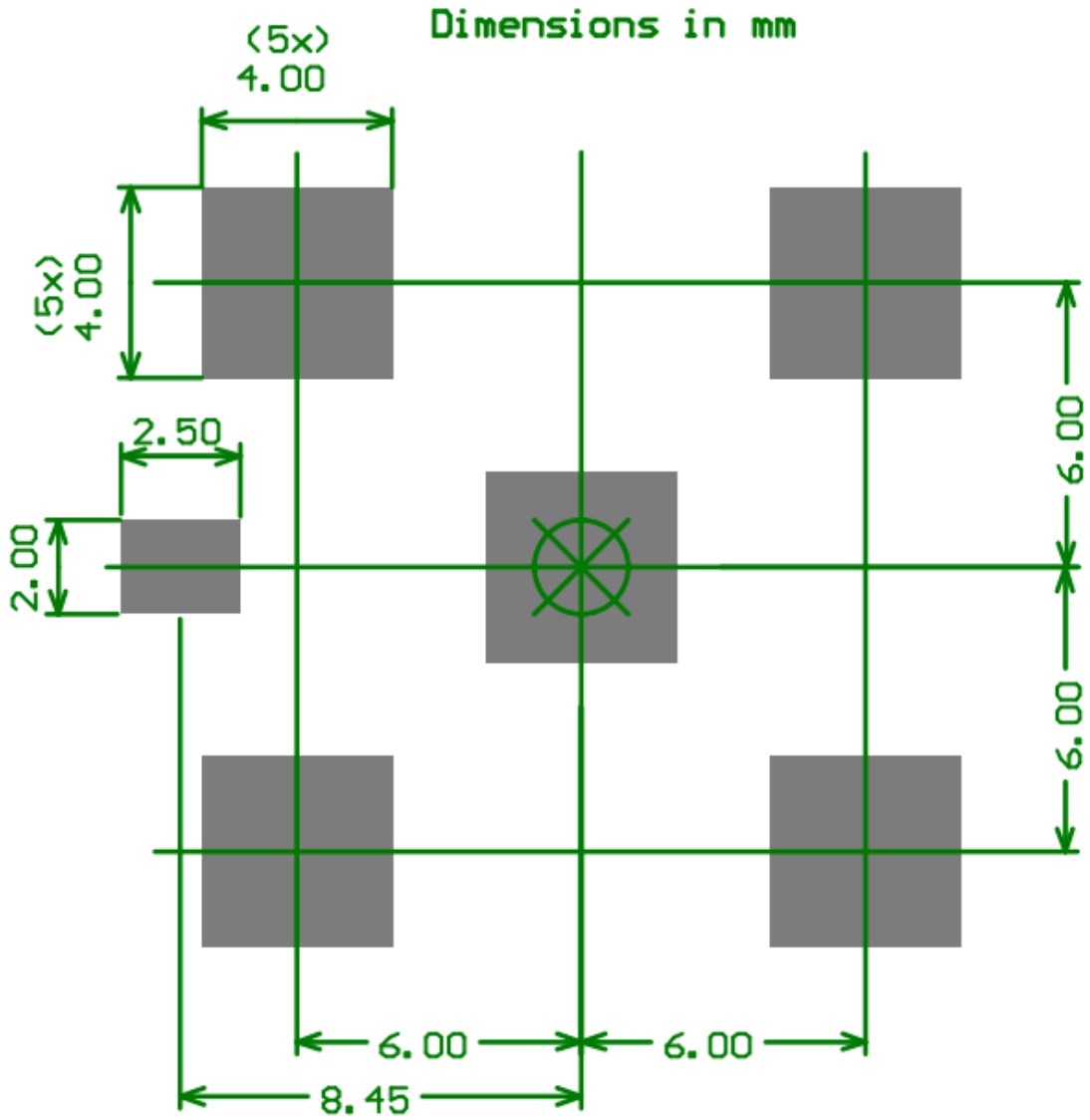

5.1.3 Soder Mask (Negative)

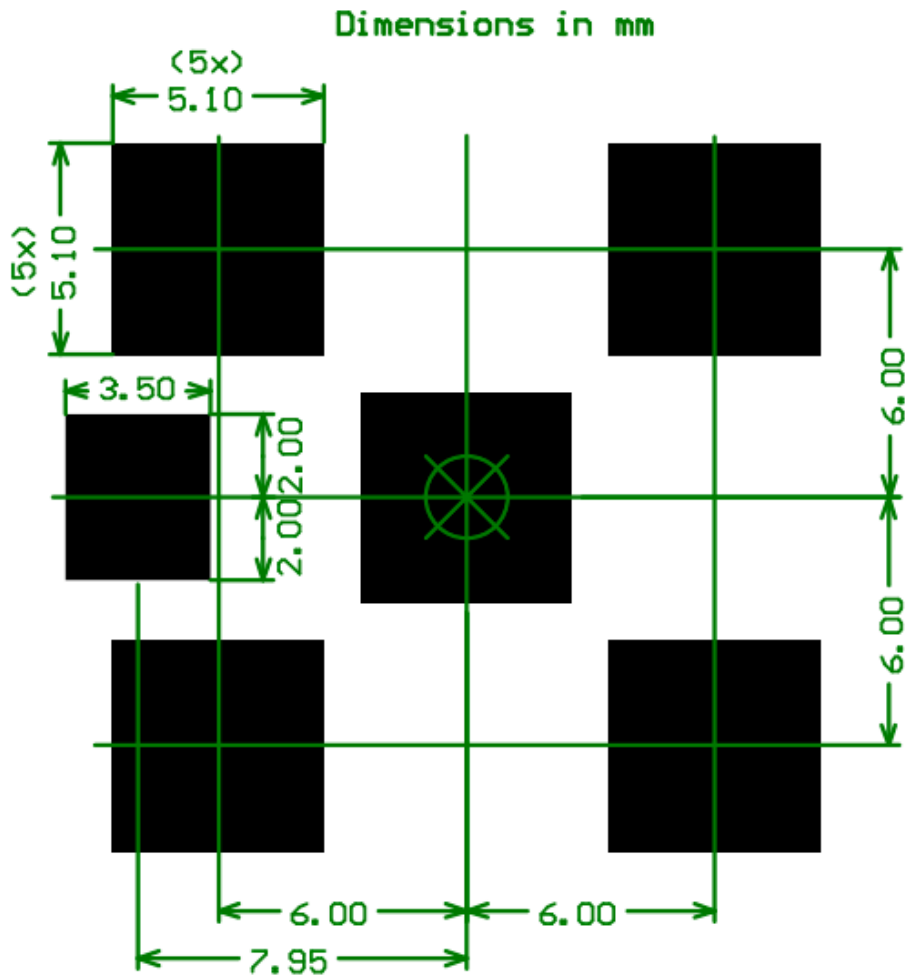

This drawing is a negative of solder mask.
Black regions are anti-mask.

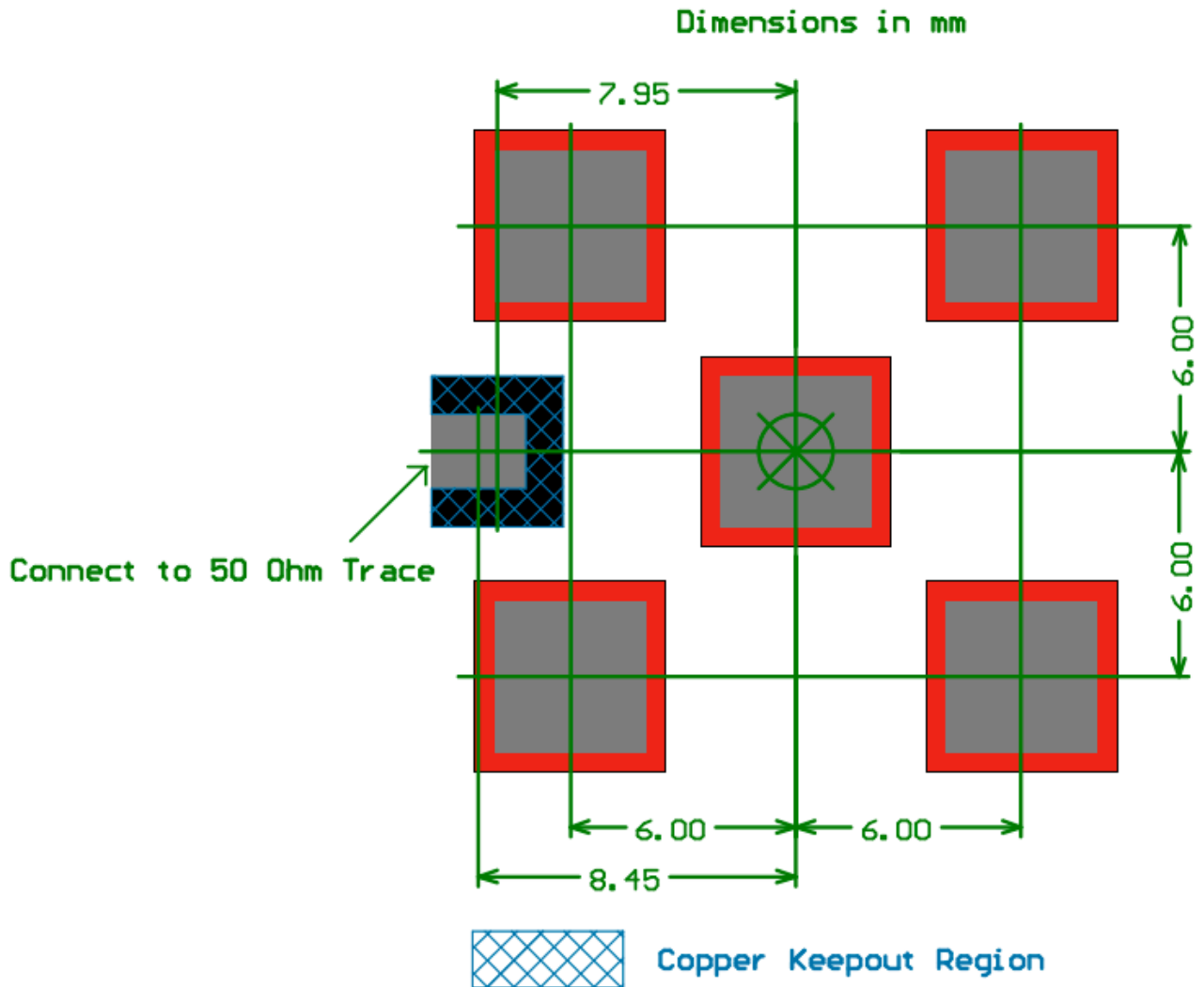

5.1.4 Footprint Composite

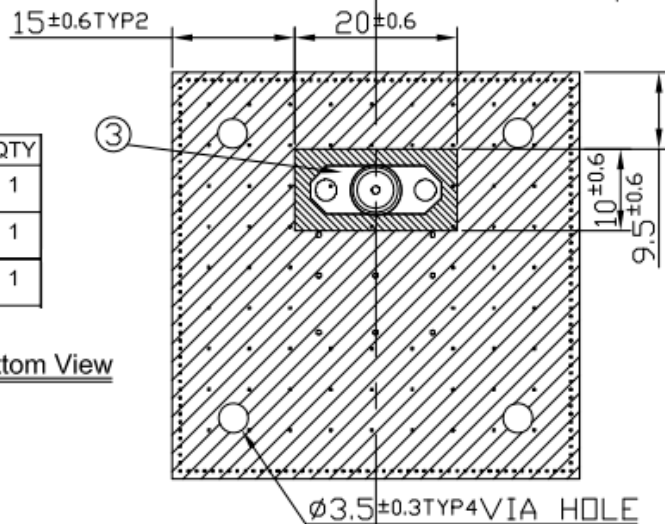
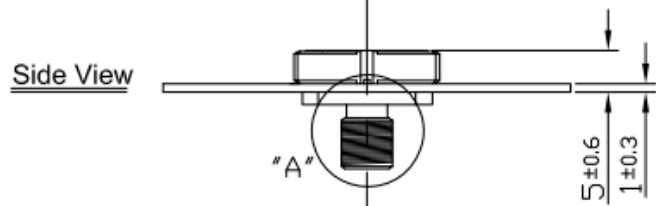
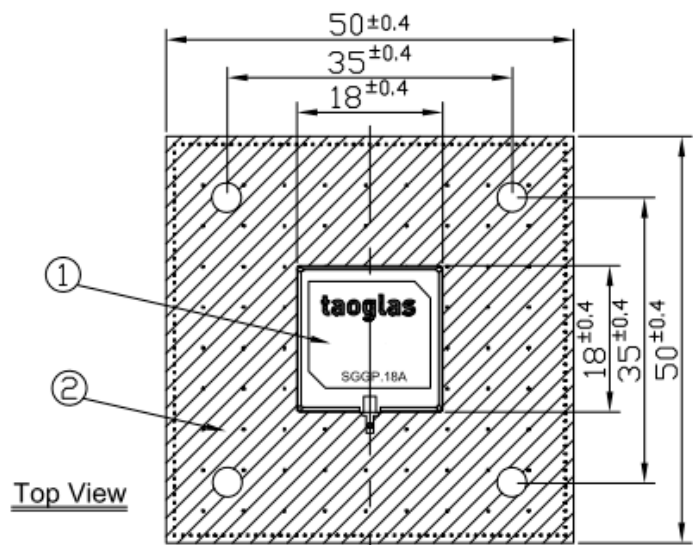
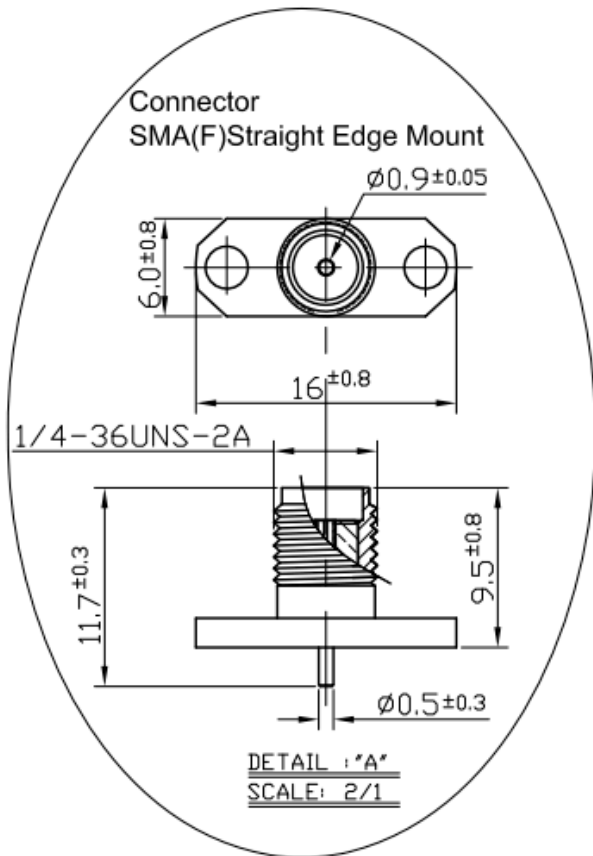

5.2 Test Jig and Dimension SGGP.18A



NOTES:

1. Solder Mask (Black) 
2. Solder Area 

	Name	Material	Finish	QTY
1	SGGP.18A Patch 18x18x4	Ceramic	Clear	1
2	FR4 PCB	FR4 1t	Black	1
3	SMA(F)Straight Edge Mount	Brass	Gold	1

5.3 SGGPD.18A

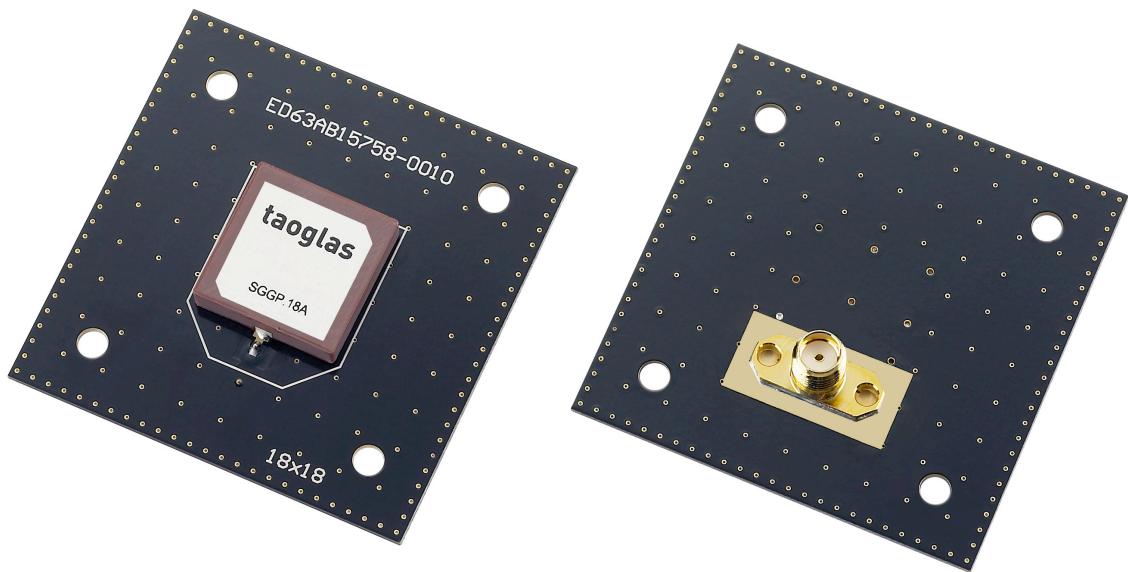

6. Recommended Reflow Soldering Profile

SGGP.18A can be assembled following Pb-free assembly. According to the Standard IPC/JEDEC J-STD-020C, the temperature profile suggested is as follows:

Phase	Profile Features	Pb-Free Assembly (SnAgCu)
PREHEAT	Temperature Min(T_{smin}) Temperature Max(T_{smax}) Time(t_s) from (T_{smin} to T_{smax})	150°C 200°C 60-120 seconds
RAMP-UP	Avg. Ramp-up Rate (T_{smax} to TP)	3°C/second(max)
REFLOW	Temperature(T_L) Total Time above T_L (t_L)	217°C 30-100 seconds
PEAK	Temperature(T_P) Time(t_p)	260°C 2-5 seconds
RAMP-DOWN	Rate	3°C/second(max)
Time from 25°C to Peak Temperature		8 minutes max.
Composition of solder paste		96.5Sn/3Ag/0.5Cu
Solder Paste Model		SHENMAO PF606-P26

The graphic shows temperature profile for component assembly process in reflow ovens

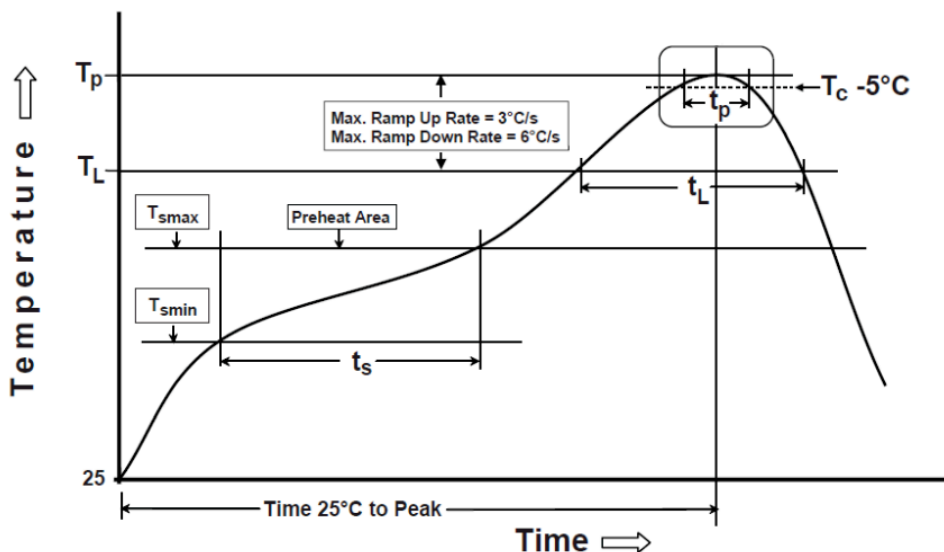

Soldering Iron condition: Soldering iron temperature $270^{\circ}\text{C} \pm 10^{\circ}\text{C}$.

Apply preheating at 120°C for 2-3 minutes. Finish soldering for each terminal within 3 seconds, if soldering iron temperature over $270^{\circ}\text{C} \pm 10^{\circ}\text{C}$ or 3 seconds, it will make cause component surface peeling or damage.

7. Packaging

200 pcs/Reel/Inner Carton
5 Reels in an outer carton

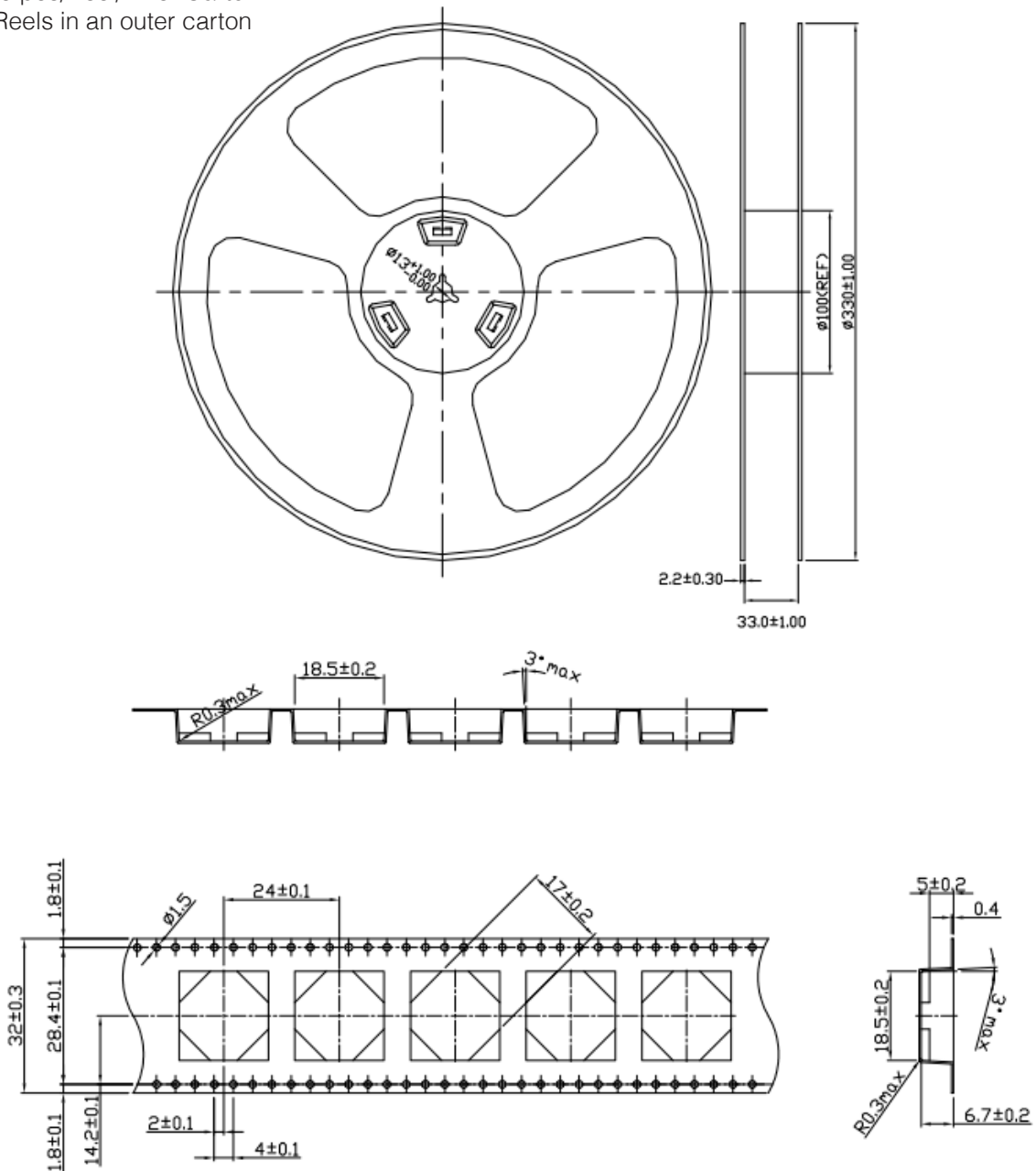

Taoglas makes no warranties based on the accuracy or completeness of the contents of this document and reserves the right to make changes to specifications and product descriptions at any time

without notice. Taoglas reserves all rights to this document and the information contained herein.

Reproduction, use or disclosure to third parties without express permission is strictly prohibited.
Copyright © Taoglas Ltd.