

1230 UltraStable™

SPECIFICATIONS

- PC Board Mountable Pressure Sensor
- 0-100 mV Output
- Current Excitation
- Gage, Differential, and Absolute
- Temperature Compensated

FEATURES

- Dual-in-Line Package
- -20°C to +85°C Compensated
- Temperature Range
- ±0.1% Non Linearity
- 1.0% Interchangeable Span (provided by gain set resistor)
- Solid State Reliability

APPLICATIONS

- Medical Instruments
- Altitude Measurement
- Process Control
- Factory Automation
- Handheld Calibrators
- Environmental Control

The 1230 is a high-performance temperature compensated, piezoresistive silicon pressure sensor packaged in a dual-in-line configuration. It uses Measurement Specialties' proprietary UltraStable™ die to provide excellent performance and long-term stability over wide temperatures.

Integral temperature compensation is provided over a range of -20°C to +85°C using laser-trimmed resistors. An additional laser-trimmed resistor is included to normalize pressure sensitivity variations by programming the gain of an external differential amplifier. This provides sensitivity interchangeability of ±1%. Absolute, differential and gage pressure ranges from 0-15 to 0-100 psi are available. Multiple lead and tube configurations are available for different applications.

Please refer to the 1210 and 1220 for information on products with operating pressures less than 0-15 psi. For voltage excitation, please refer to the Model 1240.

STANDARD RANGES

Range	psia	psid	psig
0 to 2		•	•
0 to 5		•	•
0 to 15	•	•	•
0 to 30	•	•	•
0 to 50	•	•	•
0 to 100	•	•	•

PERFORMANCE SPECIFICATIONS

Unless otherwise specified: Supply Current: 1.5 mA, Ambient Temperature: 25°C

PARAMETERS	MIN	TYP	MAX	UNITS	NOTES
Span	75	100	150	mV	1
Zero Pressure Output	-2		2	mV	
Pressure Non Linearity	-0.1	±0.05	0.1	%Span	2
Pressure Hysteresis	-0.1	±0.01	0.1	%Span	
Input Resistance	2200	4000	5800	Ω	
Output Resistance		4200		Ω	
Temperature Error – Span	-0.5	±0.3	0.5	%Span	3
Temperature Error – Zero	-0.5	±0.1	0.5	%Span	3
Temperature Coefficient – Resistance		0.15		%/°C	3
Thermal Hysteresis – Zero		±0.05		%Span	3
Short Term Stability (Offset & Span)		±0.05		%Span	4
Long Term Stability (Offset & Span)		±0.1		%Span	5
Supply Current	0.5	1.5	2.0	mA	
Response Time (10% to 90%)		1.0		ms	6
Output Noise (10Hz to 1kHz)		1.0		μV p-p	
Pressure Overload			3X	Rated	7
Compensated Temperature	-20		+85	°C	8
Operating Temperature	-40		+125	°C	
Storage Temperature	-50		+150	°C	
Weight			3	grams	
Solder Temperature	250°C Max 5 Sec.				
Media	Non-Corrosive Dry Gases Compatible with Silicon, Pyrex, RTV, Gold, Ceramic, Nickel, and Aluminum				

Notes

1. Ratiometric to supply current. Span for 2PSI is 30 to 60mV.
2. Best fit straight line. Non Linearity for 2 PSI is ±0.2% and 5 PSI is ± 0.5%.
3. Maximum temperature error between -20°C and +85°C with respect to 25°C.
4. Short term stability over 7 days with constant current and temperature.
5. Long term stability over a one year period with constant current and temperature.
6. For a zero-to-full scale pressure step change.
7. 2X maximum for 100 psi device.
8. For pressures ranges below 15 psi, compensated temperature range is 0°C to 50°C and thermal error of offset is ±1%.

DIMENSIONS

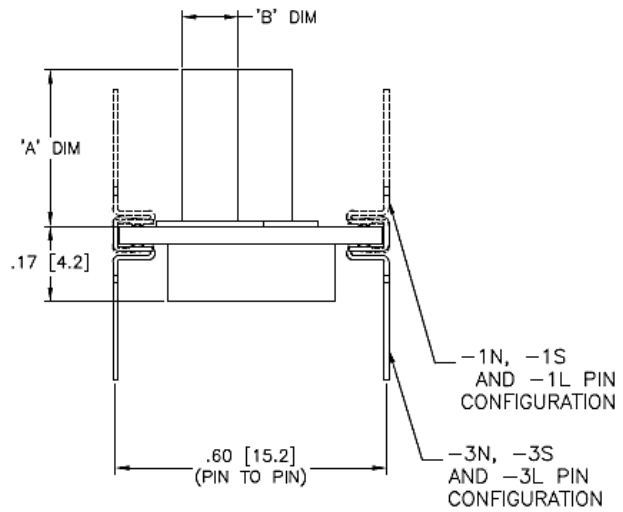
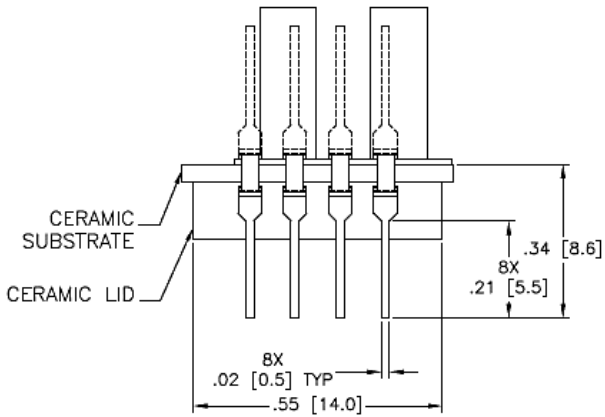
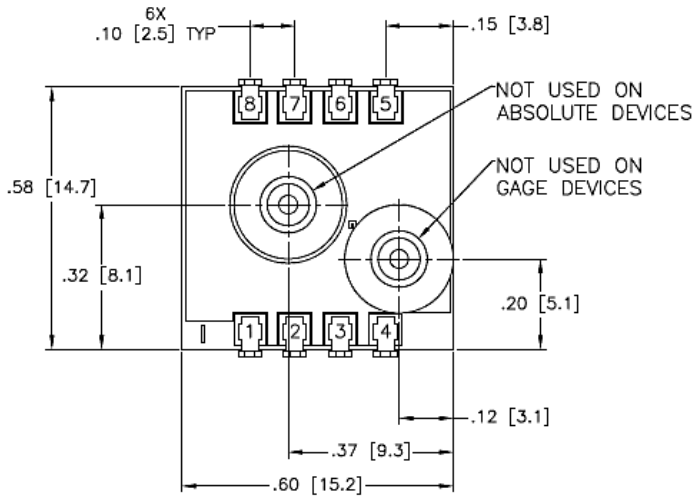

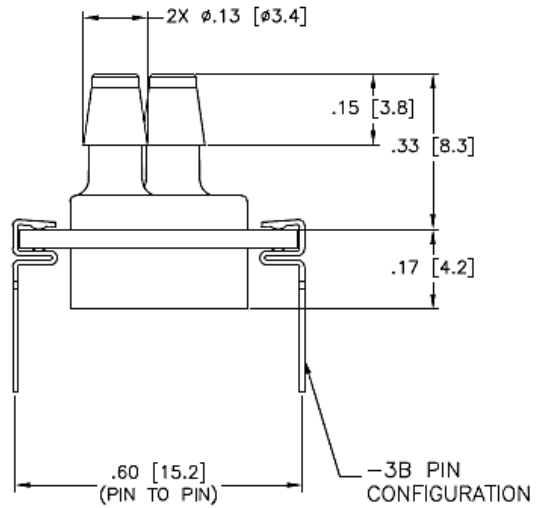
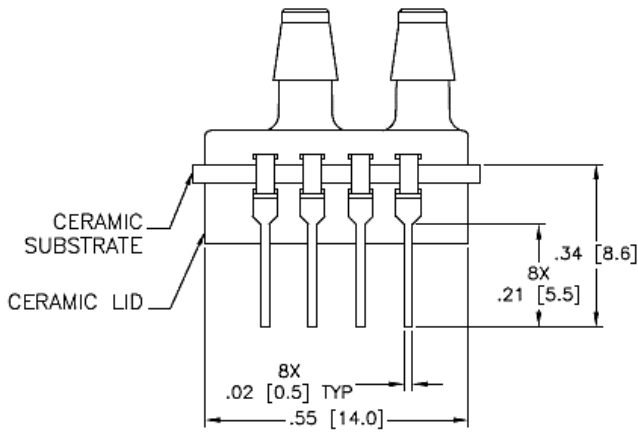
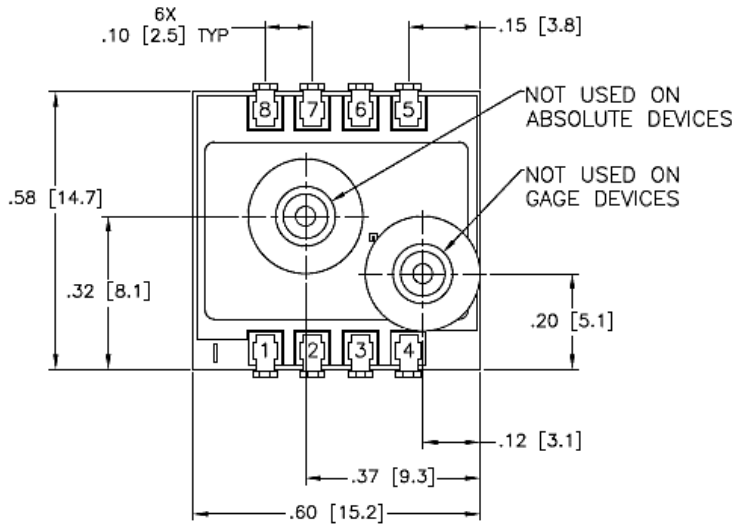

Sensor Pinout

Pin No.	Function
1	-OUT
2	-EX
3	+OUT
4	+EX
5,6	GAIN
7,8	TEST

Vent Tube Dimensions

Model	'A' Dim	'B' Dim
1N / 3N	N/A	N/A
1L / 3L	.490±.005 [12.45±0.13]	Ø.127±.005 [ø3.23±.13]
1S / 3S	.325±.005 [8.26±0.13]	Ø.125±.005 [ø.3.18±0.13]

CONNECTIONS

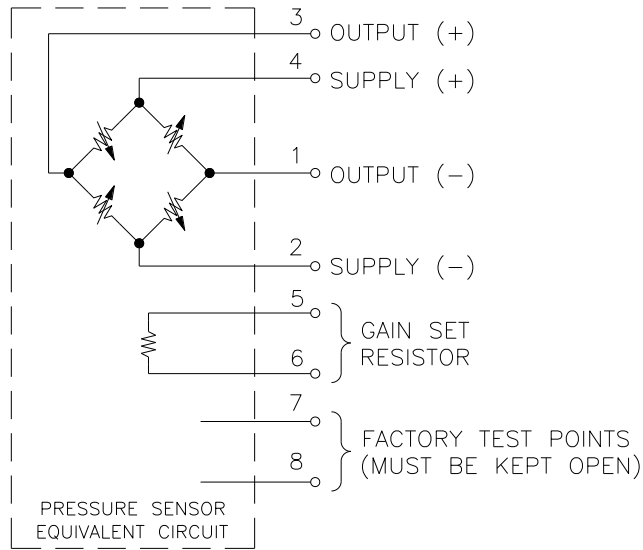

APPLICATION SCHEMATIC

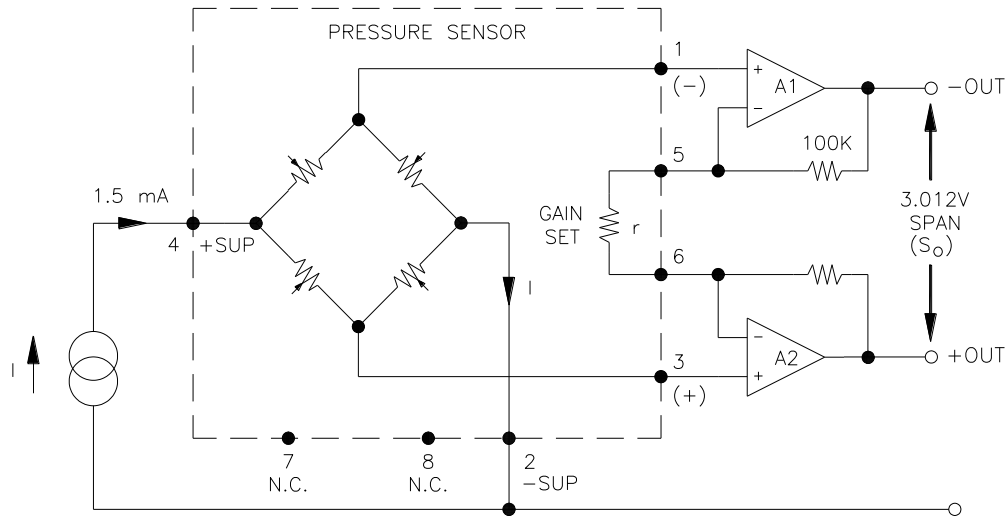

APPLICATION SCHEMATIC

ORDERING INFORMATION

1230 – 030 A – 3 N

Pressure Range [psi]	
	002
	005
	015
	030
	050
	100

Pressure Type	
G	Gage
A	Absolute
D	Differential

Vent Type	
L	Long Tube
S	Short Tube
N	No Tube
B	Barb

Lead Configuration	
1	Same Side as Vent Tube
3	Opposite Side as Vent Tube

NORTH AMERICA

Measurement Specialties, Inc.,
a TE Connectivity Company
Tel: +1 800-522-6752
customercare.frmt@te.com

EUROPE

Measurement Specialties (Europe), Ltd.,
a TE Connectivity Company
Tel: +31 73 624 6999
customercare.bevx@te.com

ASIA

Measurement Specialties (China), Ltd.,
a TE Connectivity Company
Tel: +86 0400-820-6015
mailto:customercare.shzn@te.com

TE.com/sensorsolutions

Measurement Specialties, Inc., a TE Connectivity company.

Measurement Specialties, TE Connectivity, TE Connectivity (logo) and EVERY CONNECTION COUNTS are trademarks. All other logos, products and/or company names referred to herein might be trademarks of their respective owners.

The information given herein, including drawings, illustrations and schematics which are intended for illustration purposes only, is believed to be reliable. However, TE Connectivity makes no warranties as to its accuracy or completeness and disclaims any liability in connection with its use. TE Connectivity's obligations shall only be as set forth in TE Connectivity's Standard Terms and Conditions of Sale for this product and in no case will TE Connectivity be liable for any incidental, indirect or consequential damages arising out of the sale, resale, use or misuse of the product. Users of TE Connectivity products should make their own evaluation to determine the suitability of each such product for the specific application.

© 2015 TE Connectivity Ltd. family of companies All Rights Reserved.