

MS1451



- PC Board Mountable Pressure Sensor
- 0-60 mV Output
- Gage and Absolute
- Low Cost



DESCRIPTION

The MS1451 is a piezoresistive silicon pressure sensor packaged in a surface mount configuration. It is intended for high volume applications where small size, light weight, low cost, and compatibility with automated assembly equipment are required.

The pressure sensor is available with a gage or absolute pressure sensing chip that is attached to a surface mountable ceramic substrate. A plastic cap is attached to the ceramic substrate, protecting the chip and providing the pressure port.

The devices are shipped in plastic anti-static shipping tubes for use with automated production equipment. The drawing shows a standard tube version. Ports are also available with a narrow hole or a large hole to interface with the pressure media.

FEATURES

- Surface Mount Package
- $\pm 0.25\%$ Pressure Non Linearity
- 3 Pressure Port Options
- Solid State Reliability
- Low Power

APPLICATIONS

- Altitude Measurement
- Barometric Pressure
- Medical Instrumentation
- Consumer Appliances
- Tire Pressure

STANDARD RANGES

Range	psia	psig
0 to 5		W, N, T
0 to 15	W, N, T	W, N, T
0 to 30	W, N, T	W, N, T
0 to 50	W, N, T	W, N, T
0 to 100	W, N, T	W, N, T
0 to 250	W, N	
0 to 500	W, N	

Port Options:

W = Wide Hole (Gel Fill option available), N = Narrow Hole, T = Tube

PERFORMANCE SPECIFICATIONS

Supply Voltage: 3 Vdc

Ambient Temperature: 25°C (unless otherwise specified)

PARAMETERS	MIN	TYP	MAX	UNITS	NOTES
Span	30	60	120	mV	1
Zero Pressure Output	-25		25	mV	
Pressure Non Linearity	-0.25		0.25	%Span	2
Pressure Hysteresis	-0.1		0.1	%Span	
Input & Output Resistance	3500	5000	6000	Ω	
Temperature Coefficient – Span		-0.13		%/°C	3
Temperature Coefficient – Zero		0.05		%/°C	3
Temperature Coefficient – Resistance		0.15		%/°C	3
Thermal Hysteresis – Zero	-0.2		0.2	%Span	3
Supply Voltage		3.0	12.0	Vdc	
Response Time (10% to 90%)		1.0		mS	4
Output Noise (10Hz to 1kHz)		1.0		μV p-p	
Long Term Stability (Offset & Span)		0.5		%Span	5
Pressure Overload			3X	Rated	6
Operating Temperature	-40		+125	°C	
Storage Temperature	-50		+150	°C	
Weight			0.3	grams	
Soldering Temperature	250°C Max 5 Sec.				7
Media	Non-Corrosive Dry Gases Compatible with Silicon, Pyrex, RTV, Gold, LCP (Liquid Crystal Polymer), and Aluminum				

Notes

1. Ratiometric to supply voltage.
2. Best fit straight line.
3. Over the temperature range 0-50°C with respect to 25°C.
4. For a zero-to-full scale pressure step change.
5. Long term stability over a one year period with constant voltage and temperature.
6. For sensors above 100 psi, the entire sensor is required to be inside the pressure chamber.
7. For mounting instructions, please refer to the application note "Mounting Instructions for SMT Pressure Sensors."

1451

DIMENSIONS

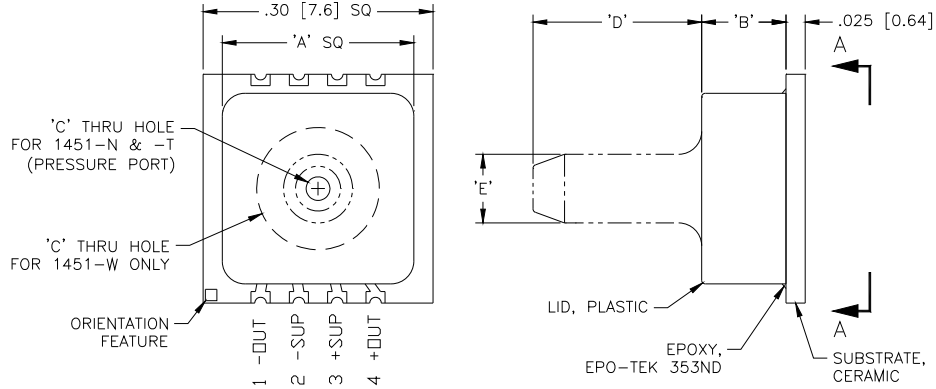

MODEL 1451 LID TABULATION			
	1451-N (NO TUBE)	1451-W (WIDE HOLE)	1451-T (TUBE)
'A'	.25 [6.4]	.25 [6.4]	.25 [6.4]
'B'	.110 [2.79]	.110 [2.79]	.110 [2.79]
'C'	∅.031 [0.78]	∅.160 [4.06]	∅.031 [0.78]
'D'			.220 [5.59]
'E'			∅.090 [2.29]

ALL DIMENSIONS ARE IN INCHES [mm]

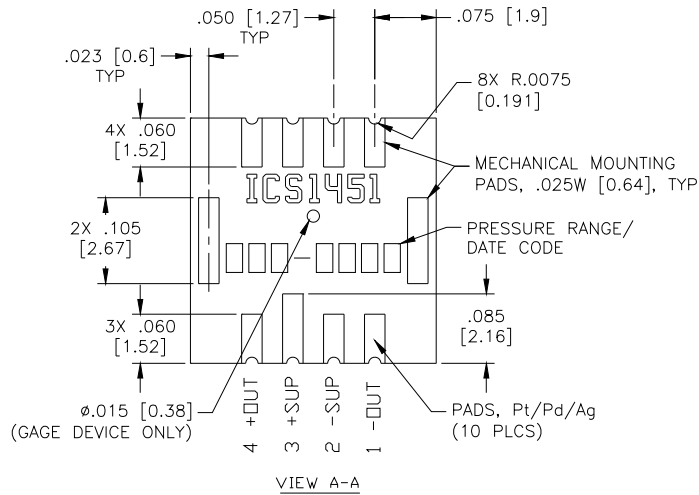

CONNECTIONS

